

CURRENT SENSOR

PRODUCT SERIES: SFG-X.XCPL/B
PRODUCT PART NUMBER: SFG-0.3CPL/B
REVISION: Ver 1.4



Sinomags Technology Co., Ltd.

Website: www.sinomags.com

CONTENT

1.	Description	2
2.	Absolute parameter	3
3.	Electrical data	4
4.	Application information	5
5.	Dimensions (in mm).....	7

1. Description

Features

- High and low level output
- Single supply voltage
- Self-check function
- Cobalt base magnetic ring.

Advantages

- Stable accuracy
- Low hysteresis
- Short response time
- Compact design

Applications

- Ground fault detection
- Converter leakage current detection
- Electric vehicle charge station
- IC-CPD
- Wallbox

Standards

- EN 50178
- IEC 62752
- IEC 61851

2. Absolute parameter

Absolute maximum ratings

Parameter	Symbol	Unit	Min	Typ	Max
Supply voltage	V _C	V			5.5
Primary rated current	I _P	A		32	40
Ambient operating temperature	T _A	°C	-40		105
Ambient storage temperature	T _A	°C	-40		105

Stresses above these ratings may cause permanent damage. Exposure to absolute maximum ratings for extended periods may degrade reliability.

Isolation parameters

Parameter	Symbol	Unit	Value
RMS voltage for AC test 50Hz/1min	V _d	kV	3
Impulse withstand voltage 1.2/50μs	V _w	kV	7
Lightning surge current 8/20μs	I _{LS}	kA	5
Comparative tracking index	CTI	V	600
Application example	-	V	600,CAT III,PD2

3. Electrical data

at $T_A = 25^\circ\text{C}$, $V_C = 5\text{ V}$.

Parameters	Symbol	Unit	Min	Typ	Max
Supply voltage	V_C	V	4.8	5	5.2
Current consumption	I_C	mA		15	
Scaling factor of the DC component $I_{\Delta N1}$ (for monitoring purpose only!)	$S_{\text{PWM-OUT}}$	%mA		3.33	
Measuring range	$I_{\Delta N, \text{max}}$	mA	-300		300
Rated residual operating current 1	$I_{\Delta N1}$	mA DC		6	
Rated residual operating current 2	$I_{\Delta N2}$	mA rms		30	
Resolution(@ $I_{\Delta N}$, $T_A = 25^\circ\text{C}$)	X	mA		<0.2	V_C
TEST-IN Input Voltage, low level	$V_{\text{TEST-IN, low}}$	V	0		0.6
TEST-IN Input Voltage, high level	$V_{\text{TEST-IN, high}}$	V	2.5		5
Response time	T_r	ms		IEC62752	
Frequency range	f_{BW}	kHz	DC		2
Primary nominal RMS current	I_M	A		32	40

4. Application information

Typical application diagram:

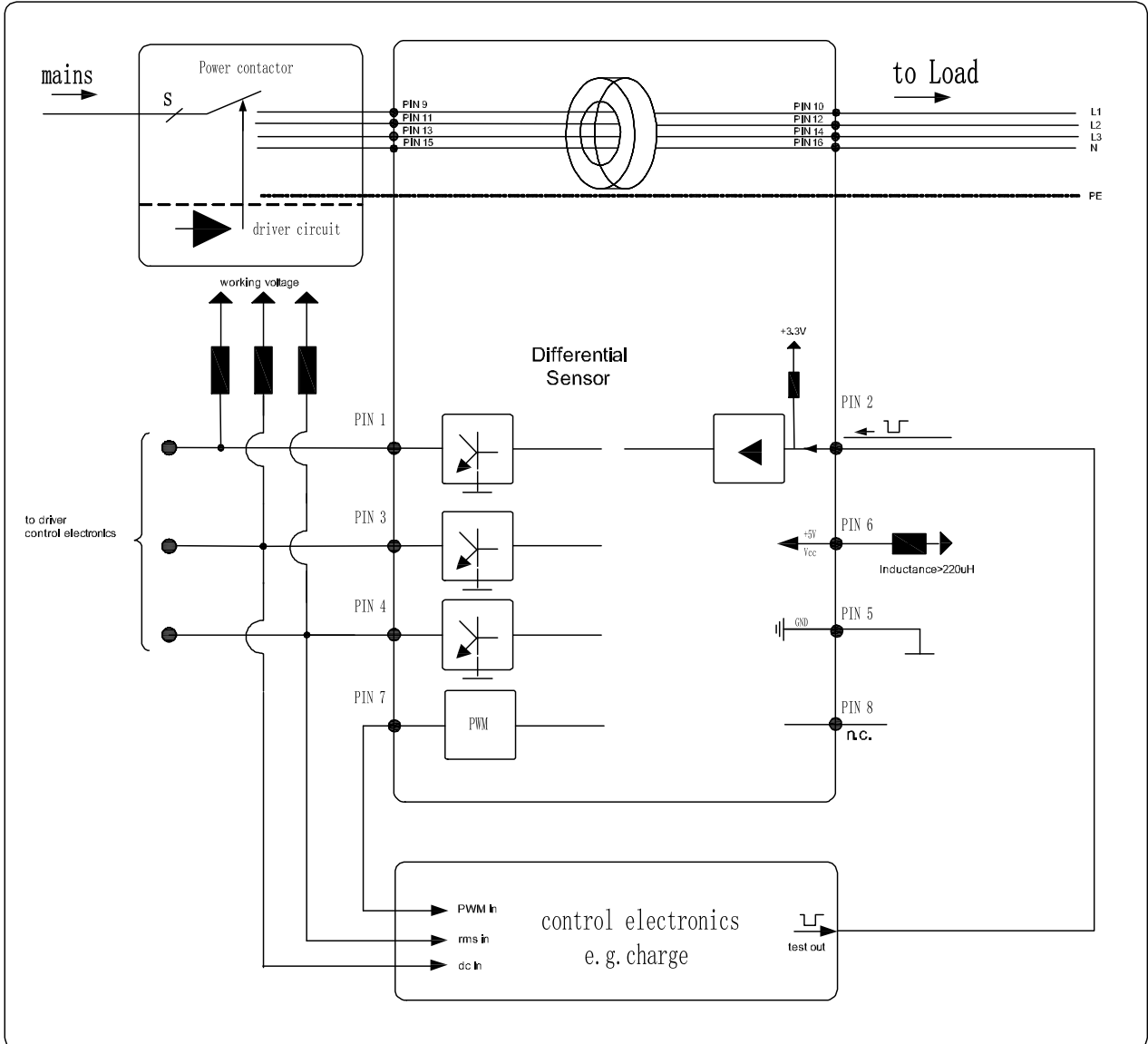

Interrupting Time (IEC62752 & IEC62955)

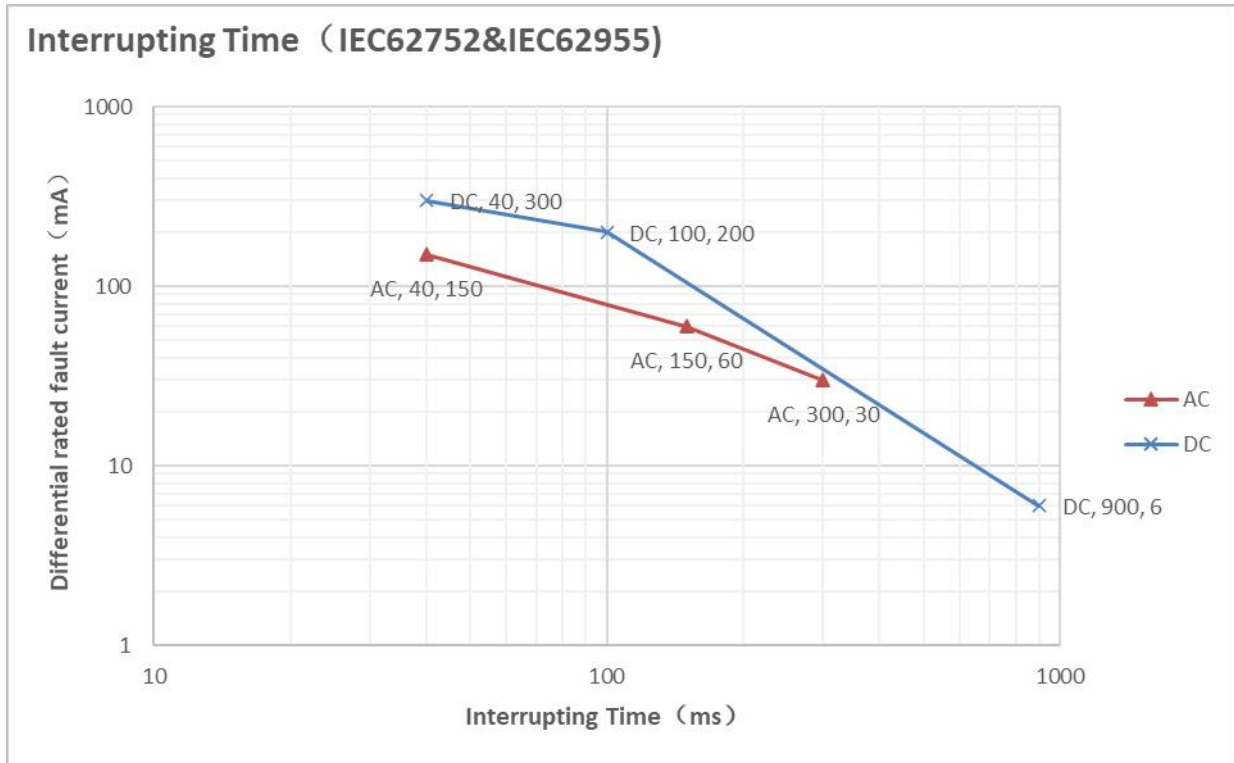

Standard type

Test currents generated during functional test

Standard	I _{dn1}	I _{dn2}
IEC 62752	8.8 mA DC	55.5 mA DC

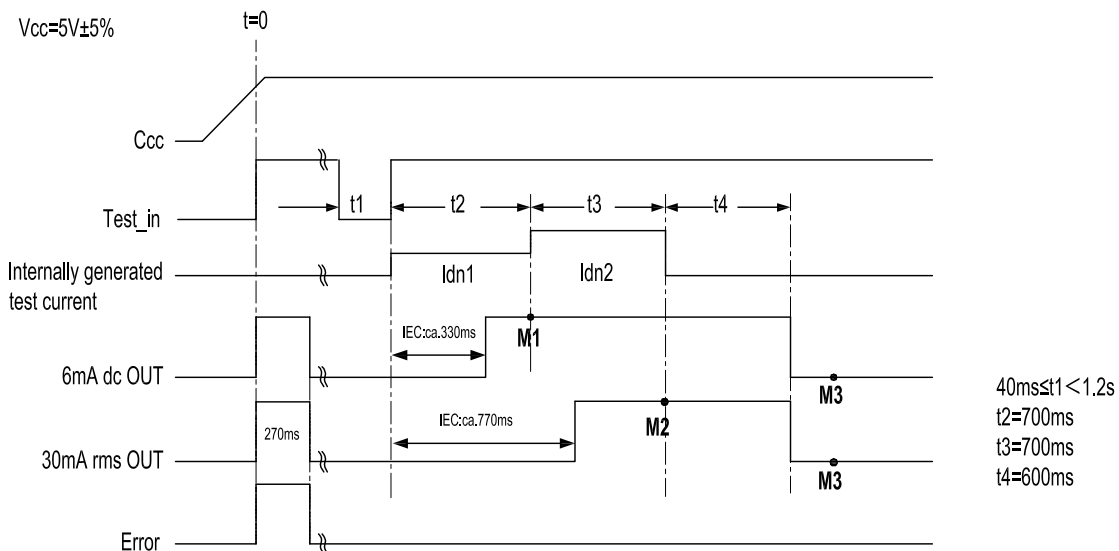

After activating the test sequence, the end product has to monitor the correct state of the switching outputs being used at the following points in time

- M1: check that 6mA dc OUT is disabled (latest time)
- M2: check that 30mA rms OUT is disabled
- M3: check that 30mA rms OUT resp. 6mA dc out is enabled

5. Dimensions (in mm)

Connections:

PIN no. 1-8: 0.46mm x 0.46mm

PIN no. 9-16: $\phi = 2.5$ mm

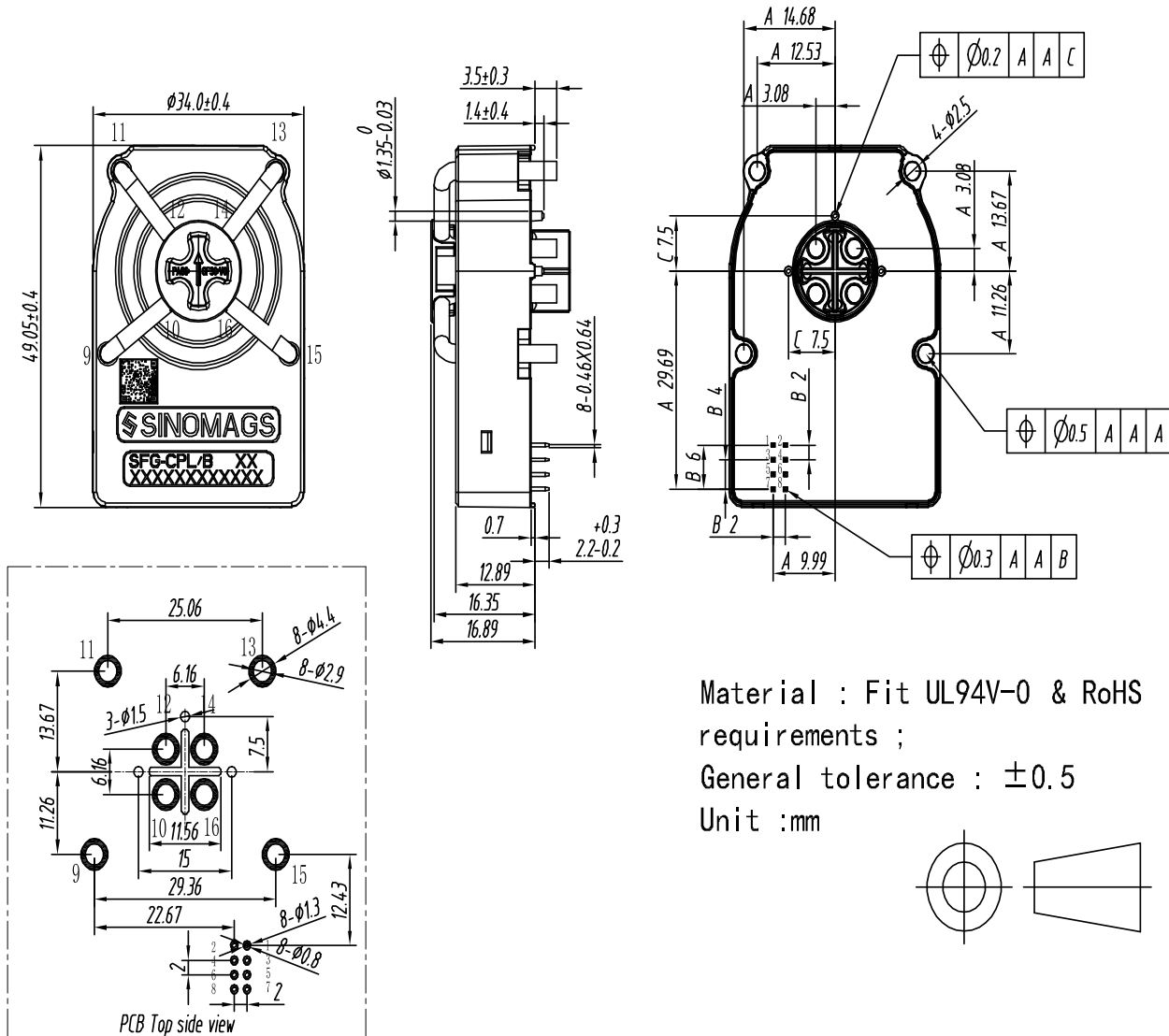

Material : Fit UL94V-0 & RoHS requirements ;
General tolerance : ± 0.5
Unit : mm

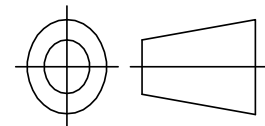

Pin description

PIN NO.	Description
PIN1 → ERROR-OUT (open collector output)	Error flag: If a system fault is detected, PIN out will change from low level(GND) to high impedance state.
PIN2 → TEST-IN	A function test including an offset measurement is activated if this PIN is connected to GND for a period of 40ms to 1.2s. If the PIN is set to GND less than 40ms or more than 1.2s, no function test will be performed. During the functional test and offset measurement, no differential current shall flow.
PIN3 → X6-OUT (open collector output)	If the residual current is below 6mA dc and no system fault occurs the output on PIN 3 is a low level(GND). In any other case output PIN 3 is in a high impedance state. If PIN 4 is high impedance, PIN 3 will also be set to high impedance.
PIN4 → X30-OUT (open collector output)	If the residual current is below 30mA rms and no system fault occurs the output on PIN 4 is a low level(GND). In any other case output PIN 3 and 4 are in a high impedance state.
PIN5 → GND	Ground connection
PIN6 → VCC	Supply voltage
PIN7 → PWM-OUT	Acc. to the DC component of residual current a duty-cycle with $f=8\text{kHz}$ is generated. This is for monitoring purposes only and shall not be used to switch the power relay. Refer to $S_{\text{PWM-OUT}} = 3.33\%/mA$
PIN8 → N.C.	Not connected
PIN9 - 16	For primary wires connection