

CURRENT SENSOR

PRODUCT SERIES: STB-LF5

PRODUCT PART NUMBER: STB-500LF5

VERSION: Ver 1.2



Sinomags Technology Co., Ltd.

Web site: www.sinomags.com

CONTENT

1.	Description	2
2.	Electrical parameters.....	3
3.	Dimensions:	4

1. Description

STB-LF5 series current sensors are based on close loop principle. The sensor can detect the current with DC, AC, pulse and irregular wave shape with current output.

Typical application

- Windmill inverters
- AC variable speed and servo motor drives
- Uninterruptible Power supplies (UPS)
- Power supplies for welding applications
- Test and measurement
- Battery supplied applications
- Switched Mode Power Supplies (SMPS)
- Static converts for DC motor drives

General parameters

Parameter	Symbol	Unit	Value
Sensor operating temperature	T_A	°C	-40 ~ 85
Storage temperature	T_S	°C	-50 ~ 90
Mass	m	g	240

Absolute parameters

Parameters	Symbol	Unit	Value
Supply voltage (-40°C...85°C)	V_{CCmax}	V	±25.2
Maximum primary conductor temperature	T_{Bmax}	°C	100
Maximum steady state primary current (-40°C...85°C)	I_{PNmax}	A	500

Ratings

Parameter	Unit	Value
Primary involved potential	V AC/DC	600
Maximum surrounding air temperature	°C	85
Primary current	A	0...500

Isolation parameters

Parameter	Symbol	Unit	Value	Remark
RMS voltage for AC test 50Hz/1 min	Ud	kV	3.8	
Impulse withstand voltage 1.2/50μs	Ūw	kV	12.5	
Clearance distance (pri. -sec)	dCl	mm	14.6	Shortest distance through air
Creepage distance (pri. -sec)	dCp	mm	15.6	Shortest path along device body
Case material	-	-	V0	According to UL 94
Comparative tracking index	CTI		600	

2. Electrical parameters

Condition: $V_{CC} = \pm 14.25V \sim \pm 25.2V$, $T_A = 25^\circ C$, unless specified.

Parameters	Symbol	Unit	Min	Typ	Max	Remark
Primary nominal RMS current	I_{PN}	A			500	
Primary current measuring range	I_{PM}	A	-800		800	
Measuring resistance	R_M	Ω			70	@ $\pm 500A$ with $\pm 14.25V$
	R_M	Ω			18	@ $\pm 800A$ with $\pm 14.25V$
	R_M	Ω			95	@ $\pm 500A$ with $\pm 17.1V$
	R_M	Ω			35	@ $\pm 800A$ with $\pm 17.1V$
	R_M	Ω			155	@ $\pm 500A$ with $\pm 22.8V$
	R_M	Ω			70	@ $\pm 800A$ with $\pm 22.8V$
Secondary nominal RMS current	I_{SN}	A	-0.1		0.1	
Turns ratio	N_S	NT		5000		
Resistance of secondary winding	R_S	Ω			52.8	@ $T_A=15^\circ C$
Supply voltage	V_{CC}	V	± 14.25		± 25.2	
Current consumption	I_{CC}	mA		$26 + I_S$ $39 + I_S$		@ $\pm 15V$ @ $\pm 25.2V$
Nominal sensitivity	S_N	mA/A		0.2		
Offset current, referred to primary	I_O	A	-1		1	
Offset current temperature drift, referred to primary	I_{OT}	A	-0.6		0.6	
Total error at I_{PN}	ε_{tot}	% of I_{PN}	-0.5 -0.6		0.5 0.6	25...70...85 $^\circ C$ -40 $^\circ C$...85 $^\circ C$
Linearity error	ε_L	% of I_{PN}	-0.1		0.1	
RMS noise current referred to pri.	I_{no}	mA		90		1Hz to 20kHz
Delay time @ 10 % of I_{PN}	t_{d10}	μs			0.5	@10% of I_{PN}
Delay time @ 90 % of I_{PN}	t_{d90}	μs			0.5	@90% of I_{PN}
Frequency bandwidth (-3dB)	BW	kHz		200		-3dB, small signal bandwidth

3. Dimensions:

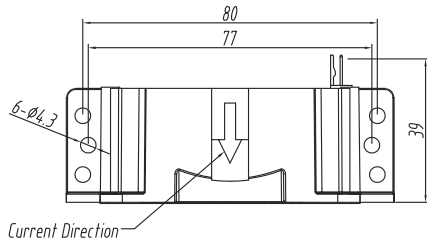

	d_a	d_{cp}
A-B	14.6mm	15.6mm

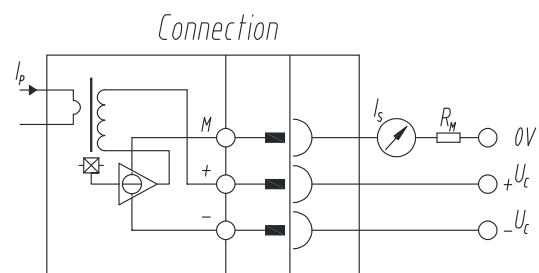
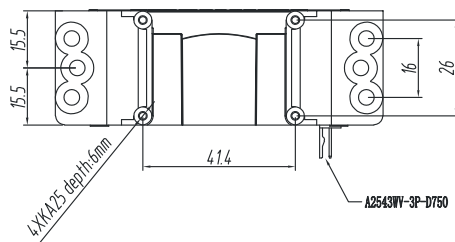
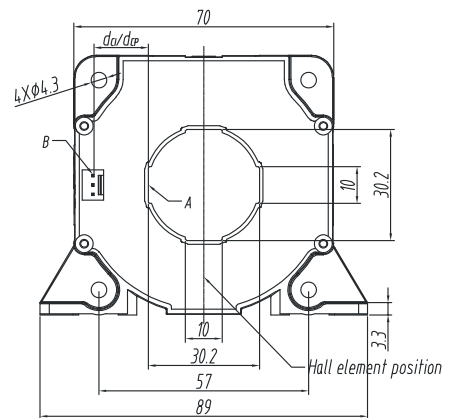
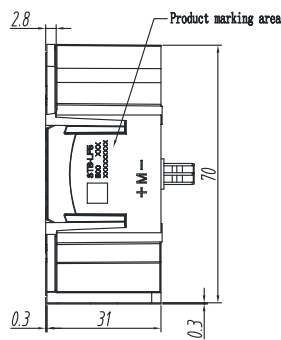
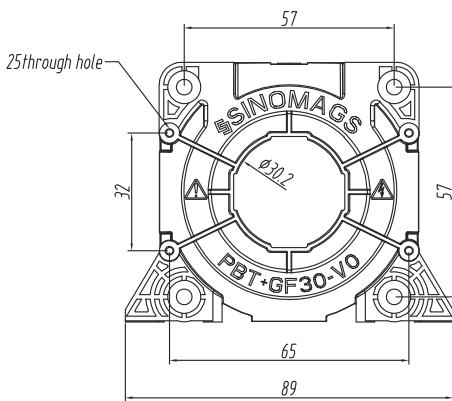

Material : Fit UL94V-0 & RoHS requirements ;
General tolerance : ± 0.5
Unit : mm

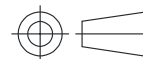

Mechanical characteristics

- General tolerance ± 0.5 mm
- Transducer fastening
 - Vertical position
 - 6 holes $\varnothing 4.3$ mm
 - 6 M4 steel screws
 - Recommended fastening torque 2.1 N·m($\pm 10\%$)
- Primary through-hole $\varnothing 30$ mm
 - Or 30mm \times 10mm
- Transducer fastening
 - Horizontal position
 - 4 holes $\varnothing 4.3$ mm
 - 4 M4 steel screws
- Connection of secondary A2543WV-3P-D750