

Current Sensor

Product Series: SHK-VBS-T

Part number: SHK-VBS-TM-900-S6
SHK-VBS-TM-1000-S6
SHK-VBS-TM-1200-S6

Version: Ver 1.4

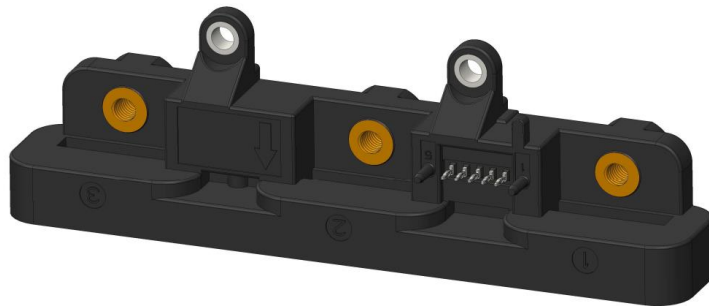

CONTENT

1. Description.....	2
2. Electrical data.....	3
3. Product definition statement.....	4
4. Electrical circuit diagram.....	5
5. Dimension & Pin definitions.....	5
6. Environmental test.....	6
7. Important notice.....	6

1. Description

The SHK-VBS-T current sensor is based on Hall and open-loop design. It is suitable for DC, AC pulsed and any kind of irregular current measurement under the isolated conditions.

Typical applications

- Electrical Power Steering
- Converters
- Motor drive application
- Battery Management

General parameter

Parameter	Symbol	Unit	Value
Working temperature	T_a	°C	-40 ~ 125
Storage temperature	T_{stg}	°C	-40 ~ 125
Mass	m	g	100

Absolute maximum rating

Parameter	Symbol	Unit	Value
Supply voltage	V_{cc}	V	-0.3 ~ 10 (Not operating)
			6.5
Electrostatic discharge voltage	U_{ESD}	kV	8 (HBM)

Remark: The unrecoverable damage may occur when the product works on the conditions over the absolute maximum ratings. Long-time working on the absolute maximum ratings may cause the degradation on performance and reliability.

Isolation parameter

Parameter	Symbol	Unit	Value	Comment
Insulation voltage	U_d	kV	2.8	RMS voltage for AC test 50Hz/1 min
Insulation resistance	R_{is}	MΩ	500	DC 1kV/1 min
Clearance distance (pri. -sec)	d_{Cl}	mm	10	Shortest distance through air
Creepage distance (pri. -sec)	d_{Cp}	mm	10	Shortest path along device body
Comparative tracking index	CTI	0	600	IEC60112
Case material			V0 according to UL 94	

2. Electrical data

Parameter	Symbol	Unit	Min	Typ	Max	Comment
Primary current measuring range	I_{PM}	A	-900		900	SHK-VBS-TM-900-S6
			-1000		1000	SHK-VBS-TM-1000-S6
			-1200		1200	SHK-VBS-TM-1200-S6
Supply voltage	V_{CC}	V	4.75	5	5.25	
Current consumption	I_{CC}	mA		45	60	@ $V_{CC} = 5.0\text{ V}$
Output voltage	V_{OUT}	V	$(V_{CC}/5) \times (V_{off} + G \times I_P)$			@ $T_a = 25^\circ\text{C}$
Quiescent voltage	V_{off}	V		2.5		@ $T_a = 25^\circ\text{C}$, $V_{CC} = 5.0\text{ V}$
Sensitivity	G	mV/A		2.22		SHK-VBS-TM-900-S6
				2		SHK-VBS-TM-1000-S6
				1.67		SHK-VBS-TM-1200-S6
Load resistance	R_L	k Ω	10		100	
Ratiometricity error	ϵ_r	%		± 0.5		@ $4.75\text{V} \leq V_{CC} \leq 5.25\text{V}$
Sensitivity error	ϵ_G	%		± 1		@ $T_a = 25^\circ\text{C}$, $V_{CC} = 5.0\text{ V}$
Electrical offset voltage error	V_{OE}	mV	-20	± 10	20	@ $T_a = 25^\circ\text{C}$, $V_{CC} = 5.0\text{ V}$
Magnetic offset voltage error	V_{OM}	mV		± 5		@ $T_a = 25^\circ\text{C}$, $V_{CC} = 5.0\text{ V}$, after $\pm I_{PM}$
Ave. Temp. coefficient of V_{OE}	TCV_{OEAV}	mV/ $^\circ\text{C}$		± 0.15		@ $-40^\circ\text{C} \leq T_a \leq 125^\circ\text{C}$
Ave. Temp. coefficient of G	TCG_{AV}	%/ $^\circ\text{C}$		± 0.03		@ $-40^\circ\text{C} \leq T_a \leq 125^\circ\text{C}$
Linearity	ϵ_L	%		± 1		@ $T_a = 25^\circ\text{C}$, $V_{CC} = 5.0\text{ V}$, $-800\text{A} < I_P < 800\text{A}$
				± 3		@ $T_a = 25^\circ\text{C}$, $V_{CC} = 5.0\text{ V}$, $800\text{A} < I_P < 1000\text{A}$ $-1000\text{A} < I_P < -800\text{A}$
Response time	T_r	μs		2	6	@ 90% of I_{PM}
Frequency bandwidth (-3 dB)	BW	kHz	40			No RC circuit
Output voltage noise	V_{no}	mVpp		10		@ DC ~ 10 kHz

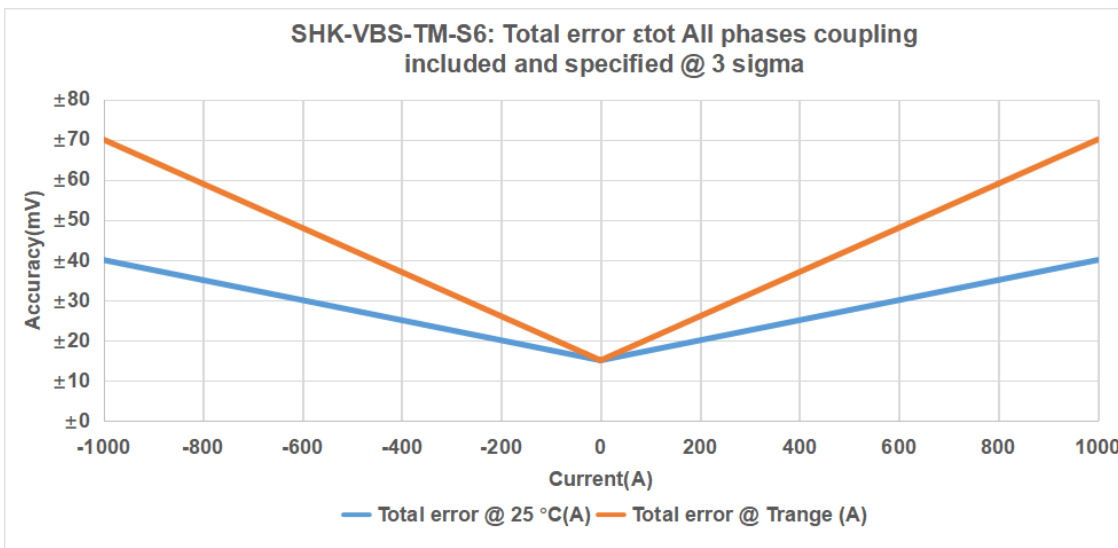

Total error specification				
$I_{PM}(A)$	@ $T_a=25^{\circ}C$, $V_{CC}=5.0V$		@ $-40^{\circ}C \leq T_a \leq 125^{\circ}C$, $V_{CC}=5.0V$	
1000	±40mV	±2%	±70mV	±3.5%
800	±35mV	±1.75%	±59mV	±2.95%
0	±15mV	±0.75%	±15mV	±0.75%
-800	±35mV	±1.75%	±59mV	±2.95%
-1000	±40mV	±2%	±70mV	±3.5%

3. Product definition statement

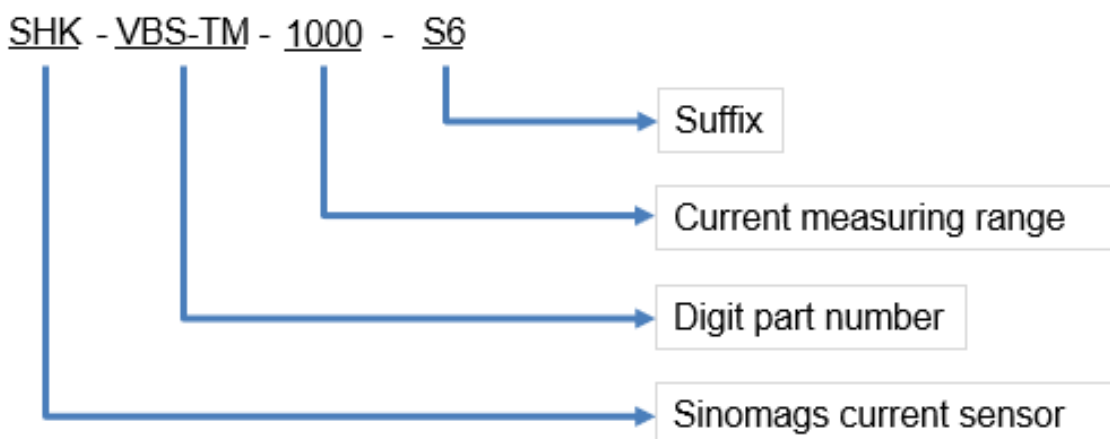

4. Electrical circuit diagram

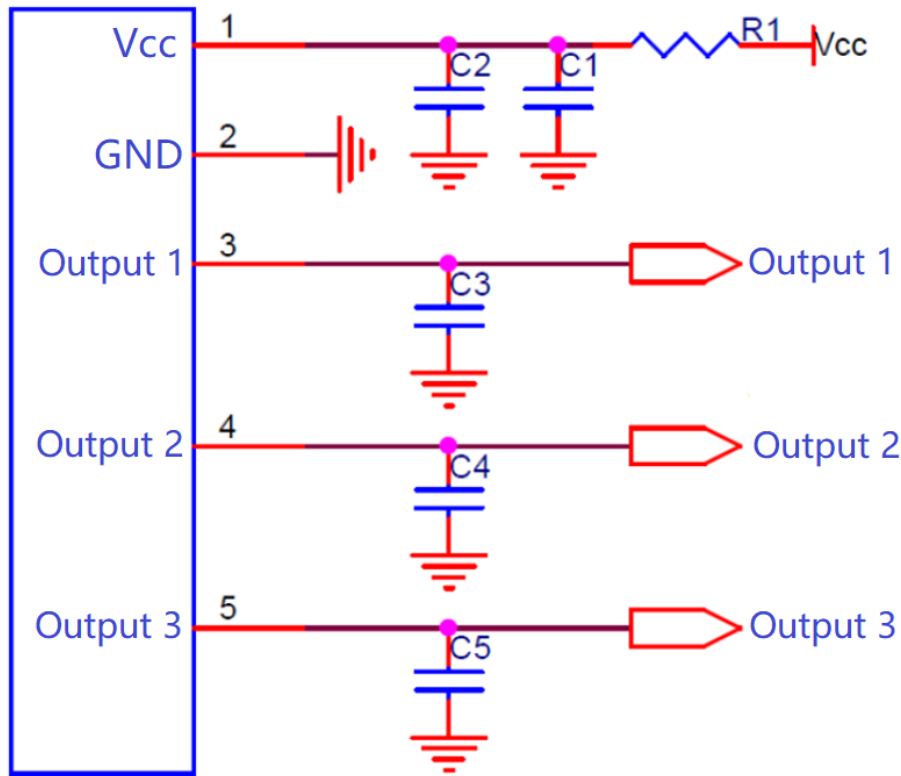

5. Dimension & Pin definitions

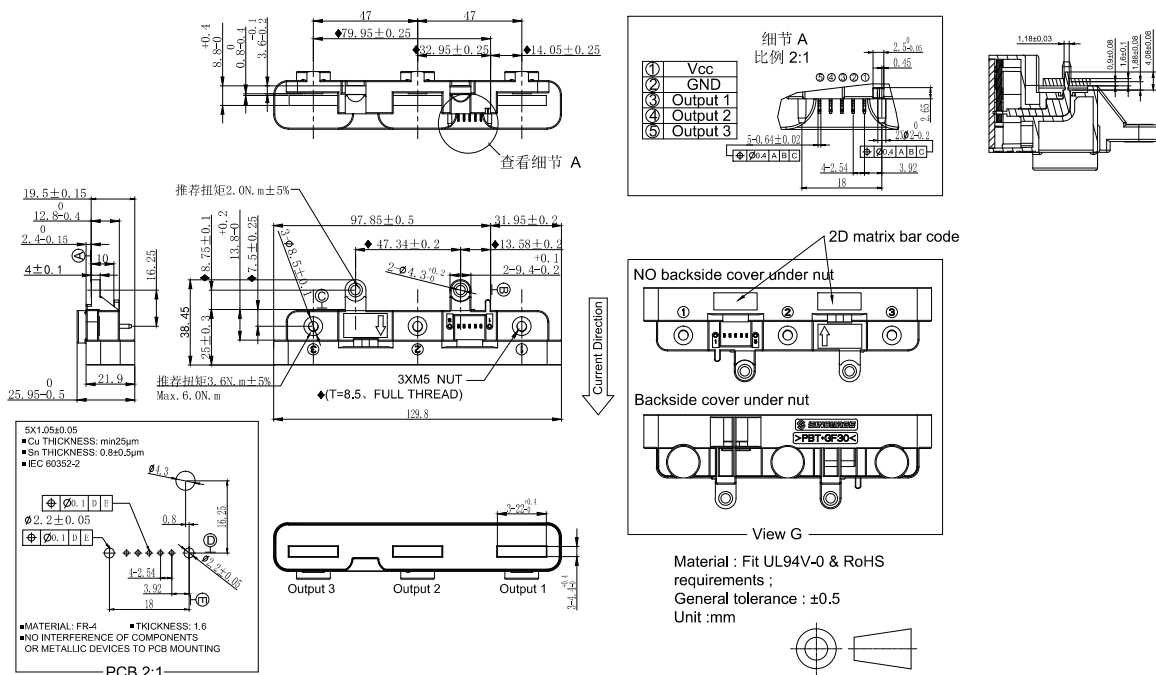

Remarks:

1. The clearance distance of the product is related to the installation mode of bus-bar .

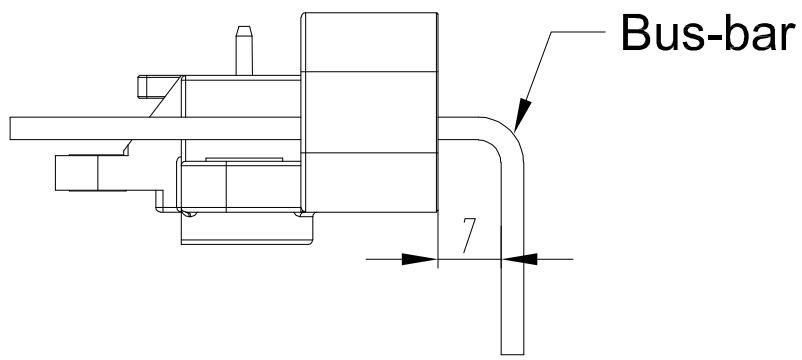

6. Environmental test

Name	Test condition
Electrical tests	
Humidity test	85°C/85%,1000hr
Thermal shock	-40°C/125°C, 1000cycles
High temperature test	125°C, 1000hr
Low temperature test	-40°C, 1000hr
Insulation voltage	2.8kV, 50Hz, 1min
Insulation resistance	DC500V, 1min
Mechanical tests	
Shocks	ISO16750-3
Vibration test	ISO16750-3
EMC tests	
Electrostatic discharges	ISO10605(07/2008)
Bulk current injection	ISO11452-4(12/2011)
Immunity to Radiated disturbances	ISO11452-2(11/2004), ALSE
Emission radiated	CISPR25(03/2008), ALSE
Immunity power line magnetic fields	ISO11452-8(06/2015)

7. Important notice

The is datasheet and any information contained therein may not be reproduced in whole or in part without the prior permission from Sinomags. The content of This information may be changed without notice for purposes such as improvement. Make sure you have the latest information when using the current sensor.