

Current Sensor

Product Series: STK-PL/Z

Part number: STK-50PL/Z
STK-50PL/Z1
STK-50PL/Z3
STK-80PL/Z
STK-100PL/Z
STK-100PL/Z2
STK-120PL/Z
STK-150PL/Z
STK-180PL/Z

Version: Ver1.3

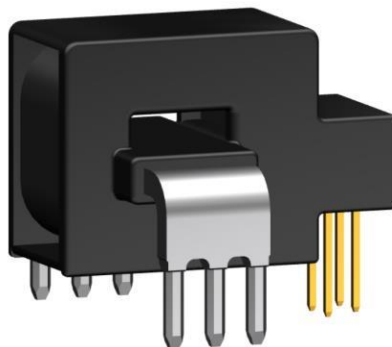

Sinomags Technology Co., Ltd

Web site: www.sinomags.com

CONTENT

1. Summary	2
2. STK-50PL/Z Electrical performance	4
3. STK-50PL/Z1 Electrical performance	5
4. STK-50PL/Z3 Electrical performance	6
5. STK-80PL/Z Electrical performance	7
6. STK-100PL/Z Electrical performance	8
7. STK-100PL/Z2 Electrical performance	9
8. STK-120PL/Z Electrical performance	10
9. STK-150PL/Z Electrical performance	11
10. STK-180PL/Z Electrical performance	12
11. Output voltage VS primary current	13
12. Accuracy characteristics in room temperature	17
13. Accuracy cross temperature	18
14. Frequency response and bandwidth	20
15. Step response time	20
16. Frequency delay performance	21
17. Recommended PCB layout	22
18. Dimension & Pin definitions	23
19. Appendix: typical application circuit	24

1. Summary

The STK-PL/Z series is based on open-loop technology and design. It is suitable for DC, AC, pulse and any type of irregular current measurement under isolated conditions. The nominal current range of STK-PL/Z current sensors includes 50A,80A,100A,120A,150A,180A.

Typical applications

- PV combiner box
- PV inverter (MPPT & AC)
- motor driver controller
- SMPS & UPS
- Battery management system

Standards

- EN50178:1997
- IEC 61010-1:2010
- IEC 61326-1:2012

General parameter

Parameter	Symbol	Unit	Value
Working temperature	T _A	°C	-40 ~ 105
Storage temperature	T _{stg}	°C	-40 ~ 105
Mass	m	g	10

Absolute maximum rating

Parameter	Symbol	Unit	Value
Supply voltage (non-destructive)	V _C	V	6.0
ESD rating (HBM)	U _{ESD}	kV	4
ESD rating (CDM)	U _{CDM}	kV	1.5

Remark: the unrecoverable damage may occur when the product works on the conditions over the absolute maximum ratings. Long-time working on the absolute maximum ratings may cause the degradation on performance and reliability.

Ratings

Parameter	Symbol	Unit	Value
Primary involved potential		V AC/DC	600
Ambient operating temperature	T_A	°C	105
Primary current	I_p	A	According to series primary current
Secondary supply voltage	U_c	V DC	5
Output voltage	V_out	V	0.1 ~ 4.9

Isolation parameter

Parameter	Symbol	Unit	Value	Comment
RMS voltage for AC test 50Hz/1 min	U _d	kV	5	
Impulse withstand voltage 1.2/50μs	Ū _w	kV	8	
Clearance distance (pri. -sec)	d _{Cl}	mm	8	Shortest distance through air
Creepage distance (pri. -sec)	d _{Cp}	mm	8	Shortest path along device body
Case material			V0 according to UL 94	
Application example		V	600	Reinforced insulation, CAT III, PD 2, non uniform field according EN 50178, IEC 61010
Application example		V	1000	Basic insulation, CAT III, PD 2, non uniform field according EN 50178, IEC 61010
Application example		V	1500	Basic insulation, CAT III, PD 2, according to IEC 62109-1 Altitude ≤ 3000 m
Application example		V	600	CAT III, PD 2, according to UL 508

2. STK-50PL/Z Electrical performance

Condition: $T_A = 25^\circ\text{C}$ $V_{cc} = 5\text{V}$ (Except special instructions)

Parameter	Symbol	Unit	Min	Typ	Max	Comment
Primary nominal current rms	I_{pn}	A		50		
Primary current measuring range	I_{pm}	A	-125		125	
Supply voltage	V_{cc}	V	4.75	5	5.25	
Current consumption	I_{cc}	mA		5	10	
Reference voltage	V_{ref}	V	2.48	2.5	2.52	Output function
Rated output voltage	V_{FS}	V		0.8		$(V_{out} - V_{ref}) @ I_{pn}$
Internal output resistance	R_{out}	Ω		1		Output
Quiescent voltage	V_{off}	V	2.48	2.5	2.52	$V_{out} @ 0\text{A}$
Electrical offset voltage	V_{oe}	mV	-10		10	$(V_{out} - V_{ref}) @ 0\text{A}$
Temperature drift of V_{oe}	V_{oe_TRange}	% V_{FS}	-1.5		1.5	$-40^\circ\text{C} \sim 105^\circ\text{C}$
Magnetic offset current	I_{om}	A	-0.25		0.25	@ $\pm 10 \times I_{pn}$
Theoretical gain	G_{th}	mV/A		16		$800\text{mV} @ I_{pn}$
Error of gain	Err_G	% G_{th}		± 1		Trimmed in the factory @ 25°C
Temperature drift of gain	G_{TR}	% G_{th}	-1.0		1.0	$-40^\circ\text{C} \sim 105^\circ\text{C}$
Rated linearity error	$Non-L_{pn}$	% I_{pn}	-0.5		0.5	$\pm I_{pn}$
Linearity error @ I_{pm}	$Non-L_{pm}$	% I_{pm}	-3		3	$\pm I_{pm}$
Reaction time	t_{ra}	μs		0.4		@ 10% of I_{pn}
Step response time	t_{res}	μs		1.5		@ 90% of I_{pn}
Delay time	t_{delay}	μs		0.8		400 kHz sine wave
Frequency bandwidth (-3dB)	BW	kHz		400		No RC circuit
Output voltage noise	V_{noise}	mVpp				
DC ~ 10 kHz			10			
DC ~ 100 kHz	15					
Accuracy @ 25°C	X	% of I_{pn}	-1		1	@ 25°C
Accuracy @ $-40^\circ\text{C} \sim 105^\circ\text{C}$	X_{TRange}	% of I_{pn}	-2		2	$-40^\circ\text{C} \sim 105^\circ\text{C}$

3. STK-50PL/Z1 Electrical performance

Condition: $T_A = 25^\circ\text{C}$ $V_{CC} = 5\text{ V}$ (Except special instructions)

Parameter	Symbol	Unit	Min	Typ	Max	Comment
Primary nominal current rms	I_{pn}	A		50		
Primary current measuring range	I_{pm}	A	-150		150	
Supply voltage	V_{CC}	V	4.75	5	5.25	
Current consumption	I_{CC}	mA		5	10	
Reference voltage	V_{ref}	V	2.48	2.5	2.52	Output function
Rated output voltage	V_{FS}	V		0.625		$(V_{out} - V_{ref}) @ I_{pn}$
Internal output resistance	R_{out}	Ω		1		Output
Quiescent voltage	V_{off}	V	2.48	2.5	2.52	$V_{out} @ 0\text{ A}$
Electrical offset voltage	V_{oe}	mV	-10		10	$(V_{out} - V_{ref}) @ 0\text{ A}$
Temperature drift of V_{oe}	V_{oe_TRange}	% V_{FS}	-1.5		1.5	$-40^\circ\text{C} \sim 105^\circ\text{C}$
Magnetic offset current	I_{om}	A	-0.25		0.25	@ $\pm 10 \times I_{pn}$
Theoretical gain	G_{th}	mV/A		12.5		625 mV @ I_{pn}
Error of gain	Err_G	% G_{th}		± 1		Trimmed in the factory @ 25°C
Temperature drift of gain	G_{TR}	% G_{th}	-1.0		1.0	$-40^\circ\text{C} \sim 105^\circ\text{C}$
Rated linearity error	Non- I_{pn}	% I_{pn}	-0.5		0.5	$\pm I_{pn}$
Linearity error @ I_{pm}	Non- I_{pm}	% I_{pm}	-3		3	$\pm I_{pm}$
Reaction time	t_{ra}	μs		0.4		@ 10% of I_{pn}
Step response time	t_{res}	μs		1.5		@ 90% of I_{pn}
Delay time	t_{delay}	μs		0.8		400 kHz sine wave
Frequency bandwidth (-3dB)	BW	kHz		400		No RC circuit
Output voltage noise	V_{noise}	mVpp		10		
DC ~ 10 kHz				15		
DC ~ 100 kHz						
Accuracy @ 25°C	X	% of I_{pn}	-1		1	@ 25°C
Accuracy @ $-40^\circ\text{C} \sim 105^\circ\text{C}$	X_{TRange}	% of I_{pn}	-2		2	$-40^\circ\text{C} \sim 105^\circ\text{C}$

4. STK-50PL/Z3 Electrical performance

Condition: $T_A = 25^\circ\text{C}$ $V_{cc} = 3.3\text{ V}$ (Except special instructions)

Parameter	Symbol	Unit	Min	Typ	Max	Comment
Primary nominal current rms	I_{pn}	A		50		
Primary current measuring range	I_{pm}	A	-150		150	
Supply voltage	V_{cc}	V	3.135	3.3	3.465	
Current consumption	I_{cc}	mA		5	10	
Reference voltage	V_{ref}	V	1.63	1.65	1.67	Output function
Rated output voltage`	V_{FS}	V		0.46		$V_{out} - V_{ref} @ I_{pn}$
Internal output resistance	R_{out}	Ω		1		$V_{out} @ 0\text{ A}$
Quiescent voltage	V_{off}	V	1.63	1.65	1.67	$V_{out} @ 0\text{ A}$
Electrical offset voltage	V_{oe}	mV	-10		10	$(V_{out} - V_{ref}) @ 0\text{ A}$
Temperature drift of Voe	V_{oe_TRange}	% V_{FS}	-1.5		1.5	$-40^\circ\text{C} \sim 105^\circ\text{C}$
Magnetic offset current	I_{om}	A	-0.25		0.25	@ $\pm 10 \times I_{pn}$
Theoretical gain	G_{th}	mV/A		9.2		460 mV @ I_{pn}
Error of gain	Err_G	% G_{th}	-0.5		0.5	Trimmed in the factory @ 25°C
Temperature drift of gain	Err_G_TRange	% V_{FS}	-1.0		1.0	$-40^\circ\text{C} \sim 105^\circ\text{C}$
Rated linearity error	Non-L	% I_{pn}	-0.5		0.5	$\pm I_{pn}$
Linearity error @ I_{pm}	Non-L	% I_{pm}	-3		3	$\pm I_{pm}$
Reaction time	t_{ra}	μs		0.4		@ 10% of I_{pn}
Step response time	t_{res}	μs		1.5		@ 90% of I_{pn}
Delay time	t_{delay}	μs		0.8		400 kHz sine wave
Frequency bandwidth (-3dB)	BW	kHz		400		No RC circuit
Output voltage noise	V_{noise}	mVpp		10		
DC ~ 10 kHz				15		
DC ~ 100 kHz						
Accuracy @ 25°C	X	% of I_{pn}	-1		1	@ 25°C
Accuracy @ $-40^\circ\text{C} \sim 105^\circ\text{C}$	X_TRange	% of I_{pn}	-3		3	$-40^\circ\text{C} \sim 105^\circ\text{C}$

5. STK-80PL/Z Electrical performance

Condition: $T_A = 25^\circ\text{C}$ $V_{cc} = 5\text{V}$ (Except special instructions)

Parameter	Symbol	Unit	Min	Typ	Max	Comment
Primary nominal current rms	I_{pn}	A		80		
Primary current measuring range	I_{pm}	A	-200		200	
Supply voltage	V_{cc}	V	4.75	5	5.25	
Current consumption	I_{cc}	mA		5	10	
Reference voltage	V_{ref}	V	2.48	2.5	2.52	Output function
Rated output voltage	V_{FS}	V		0.8		$(V_{out} - V_{ref}) @ I_{pn}$
Internal output resistance	R_{out}	Ω		1		Output
Quiescent voltage	V_{off}	V	2.48	2.5	2.52	$V_{out} @ 0\text{A}$
Electrical offset voltage	V_{oe}	mV	-10		10	$(V_{out} - V_{ref}) @ 0\text{A}$
Temperature drift of V_{oe}	V_{oe_TRange}	% V_{FS}	-1.5		1.5	$-40^\circ\text{C} \sim 105^\circ\text{C}$
Magnetic offset current	I_{om}	A	-0.25		0.25	@ $\pm 10 \times I_{pn}$
Theoretical gain	G_{th}	mV/A		10		800 mV @ I_{pn}
Error of gain	Err_G	% G_{th}		± 1		Trimmed in the factory @ 25°C
Temperature drift of gain	G_{TR}	% G_{th}	-1.0		1.0	$-40^\circ\text{C} \sim 105^\circ\text{C}$
Rated linearity error	$Non-L_{pn}$	% I_{pn}	-0.5		0.5	$\pm I_{pn}$
Linearity error @ I_{pm}	$Non-L_{pm}$	% I_{pm}	-3		3	$\pm I_{pm}$
Reaction time	t_{ra}	μs		0.4		@ 10% of I_{pn}
Step response time	t_{res}	μs		1.5		@ 90% of I_{pn}
Delay time	t_{delay}	μs		0.8		400 kHz sine wave
Frequency bandwidth (-3dB)	BW	kHz		400		No RC circuit
Output voltage noise	V_{noise}	mVpp		10		
DC ~ 10 kHz				15		
DC ~ 100 kHz						
Accuracy @ 25°C	X	% of I_{pn}	-1		1	@ 25°C
Accuracy @ $-40^\circ\text{C} \sim 105^\circ\text{C}$	X_{TRange}	% of I_{pn}	-2		2	$-40^\circ\text{C} \sim 105^\circ\text{C}$

6. STK-100PL/Z Electrical performance

Condition: $T_A = 25^\circ\text{C}$ $V_{cc} = 5\text{ V}$ (Except special instructions)

Parameter	Symbol	Unit	Min	Typ	Max	Comment
Primary nominal current rms	I_{pn}	A		100		
Primary current measuring range	I_{pm}	A	-250		250	
Supply voltage	V_{cc}	V	4.75	5	5.25	
Current consumption	I_{cc}	mA		5	10	
Reference voltage	V_{ref}	V	2.48	2.5	2.52	Output function
Rated output voltage	V_{FS}	V		0.8		$(V_{out} - V_{ref}) @ I_{pn}$
Internal output resistance	R_{out}	Ω		1		Output
Quiescent voltage	V_{off}	V	2.48	2.5	2.52	$V_{out} @ 0\text{ A}$
Electrical offset voltage	V_{oe}	mV	-10		10	$(V_{out} - V_{ref}) @ 0\text{ A}$
Temperature drift of V_{oe}	V_{oe_TRange}	% V_{FS}	-1.5		1.5	$-40^\circ\text{C} \sim 105^\circ\text{C}$
Magnetic offset current	I_{om}	A	-0.25		0.25	@ $\pm 10 \times I_{pn}$
Theoretical gain	G_{th}	mV/A		8		800 mV @ I_{pn}
Error of gain	Err_G	% G_{th}		± 1		Trimmed in the factory @ 25°C
Temperature drift of gain	G_{TR}	% G_{th}	-1.0		1.0	$-40^\circ\text{C} \sim 105^\circ\text{C}$
Rated linearity error	$Non-L_{pn}$	% I_{pn}	-0.5		0.5	$\pm I_{pn}$
Linearity error @ I_{pm}	$Non-L_{pm}$	% I_{pm}	-3		3	$\pm I_{pm}$
Reaction time	t_{ra}	μs		0.4		@ 10% of I_{pn}
Step response time	t_{res}	μs		1.5		@ 90% of I_{pn}
Delay time	t_{delay}	μs		0.8		400 kHz sine wave
Frequency bandwidth (-3dB)	BW	kHz		400		No RC circuit
Output voltage noise	V_{noise}	mVpp		10		
DC ~ 10 kHz				15		
DC ~ 100 kHz						
Accuracy @ 25°C	X	% of I_{pn}	-1		1	@ 25°C
Accuracy @ $-40^\circ\text{C} \sim 105^\circ\text{C}$	X_{TRange}	% of I_{pn}	-2		2	$-40^\circ\text{C} \sim 105^\circ\text{C}$

7. STK-100PL/Z2 Electrical performance

Condition: $T_A = 25^\circ\text{C}$ $V_{cc} = 5\text{ V}$ (Except special instructions)

Parameter	Symbol	Unit	Min	Typ	Max	Comment
Primary nominal current rms	I _{pn}	A		100		
Primary current measuring range	I _{pm}	A	-200		200	
Supply voltage	V _{cc}	V	4.75	5	5.25	
Current consumption	I _{cc}	mA		5	10	
Reference voltage	V _{ref}	V	2.48	2.5	2.52	Output function
Rated output voltage	V _{FS}	V		0.8		(V _{out} - V _{ref}) @ I _{pn}
Internal output resistance	R _{out}	Ω		1		Output
Quiescent voltage	V _{off}	V	2.48	2.5	2.52	V _{out} @ 0 A
Electrical offset voltage	V _{oe}	mV	-10		10	(V _{out} - V _{ref}) @ 0 A
Temperature drift of V _{oe}	V _{oe} _TRange	%V _{FS}	-1.5		1.5	-40°C ~ 105°C
Magnetic offset current	I _{om}	A	-0.25		0.25	@ ±10 x I _{pn}
Theoretical gain	G _{th}	mV/A		8		800 mV @ I _{pn}
Error of gain	Err _G	%G _{th}		±1		Trimmed in the factory @ 25°C
Temperature drift of gain	G _{TR}	%G _{th}	-1.0		1.0	-40°C ~ 105°C
Rated linearity error	Non-L _{pn}	%I _{pn}	-0.5		0.5	±I _{pn}
Linearity error @ I _{pm}	Non-L _{pm}	%I _{pm}	-3		3	±I _{pm}
Reaction time	t _{ra}	μs		0.4		@ 10% of I _{pn}
Step response time	t _{res}	μs		1.5		@ 90% of I _{pn}
Delay time	t _{delay}	μs		0.8		400 kHz sine wave
Frequency bandwidth (-3dB)	BW	kHz		400		No RC circuit
Output voltage noise	V _{noise}	mVpp		10		
DC ~ 10 kHz				15		
DC ~ 100 kHz						
Accuracy @ 25°C	X	% of I _{pn}	-1		1	@ 25°C
Accuracy @ -40°C ~ 105°C	X_TRange	% of I _{pn}	-2		2	-40°C ~ 105°C

8. STK-120PL/Z Electrical performance

Condition: $T_A = 25^\circ\text{C}$ $V_{cc} = 5\text{ V}$ (Except special instructions)

Parameter	Symbol	Unit	Min	Typ	Max	Comment
Primary nominal current rms	I _{pn}	A		120		
Primary current measuring range	I _{pm}	A	-300		300	
Supply voltage	V _{cc}	V	4.75	5	5.25	
Current consumption	I _{cc}	mA		5	10	
Reference voltage	V _{ref}	V	2.48	2.5	2.52	Output function
Rated output voltage	V _{FS}	V		0.8		(V _{out} - V _{ref}) @ I _{pn}
Internal output resistance	R _{out}	Ω		1		Output
Quiescent voltage	V _{off}	V	2.48	2.5	2.52	V _{out} @ 0 A
Electrical offset voltage	V _{oe}	mV	-10		10	(V _{out} - V _{ref}) @ 0 A
Temperature drift of V _{oe}	V _{oe} _TRange	%V _{FS}	-1.5		1.5	-40°C ~ 105°C
Magnetic offset current	I _{om}	A	-0.25		0.25	@ ±10 x I _{pn}
Theoretical gain	G _{th}	mV/A		6.667		800 mV @ I _{pn}
Error of gain	Err _G	%G _{th}		±1		Trimmed in the factory @ 25°C
Temperature drift of gain	G _{TR}	%G _{th}	-1.0		1.0	-40°C ~ 105°C
Rated linearity error	Non-L _{pn}	%I _{pn}	-0.5		0.5	±I _{pn}
Linearity error @ I _{pm}	Non-L _{pm}	%I _{pm}	-3		3	±I _{pm}
Reaction time	t _{ra}	μs		0.4		@ 10% of I _{pn}
Step response time	t _{res}	μs		1.5		@ 90% of I _{pn}
Delay time	t _{delay}	μs		0.8		400 kHz sine wave
Frequency bandwidth (-3dB)	BW	kHz		400		No RC circuit
Output voltage noise	V _{noise}	mVpp		10		
DC ~ 10 kHz				15		
DC ~ 100 kHz						
Accuracy @ 25°C	X	% of I _{pn}	-1		1	@ 25°C
Accuracy @ -40°C ~ 105°C	X_TRange	% of I _{pn}	-2		2	-40°C ~ 105°C

9. STK-150PL/Z Electrical performance

Condition: $T_A = 25^\circ\text{C}$ $V_{cc} = 5\text{ V}$ (Except special instructions)

Parameter	Symbol	Unit	Min	Typ	Max	Comment
Primary nominal current rms	I_{pn}	A		150		
Primary current measuring range	I_{pm}	A	-375		375	
Supply voltage	V_{cc}	V	4.75	5	5.25	
Current consumption	I_{cc}	mA		5	10	
Reference voltage	V_{ref}	V	2.48	2.5	2.52	Output function
Rated output voltage	V_{FS}	V		0.8		$(V_{out} - V_{ref}) @ I_{pn}$
Internal output resistance	R_{out}	Ω		1		Output
Quiescent voltage	V_{off}	V	2.48	2.5	2.52	$V_{out} @ 0\text{ A}$
Electrical offset voltage	V_{oe}	mV	-10		10	$(V_{out} - V_{ref}) @ 0\text{ A}$
Temperature drift of V_{oe}	V_{oe_TRange}	% V_{FS}	-1.5		1.5	$-40^\circ\text{C} \sim 105^\circ\text{C}$
Magnetic offset current	I_{om}	A	-0.25		0.25	@ $\pm 10 \times I_{pn}$
Theoretical gain	G_{th}	mV/A		5.33		800 mV @ I_{pn}
Error of gain	Err_G	% G_{th}		± 1		Trimmed in the factory @ 25°C
Temperature drift of gain	G_{TR}	% G_{th}	-1.0		1.0	$-40^\circ\text{C} \sim 105^\circ\text{C}$
Rated linearity error	$Non-L_{pn}$	% I_{pn}	-0.5		0.5	$\pm I_{pn}$
Linearity error @ I_{pm}	$Non-L_{pm}$	% I_{pm}	-3		3	$\pm I_{pm}$
Reaction time	t_{ra}	μs		0.4		@ 10% of I_{pn}
Step response time	t_{res}	μs		1.5		@ 90% of I_{pn}
Delay time	t_{delay}	μs		0.8		400 kHz sine wave
Frequency bandwidth (-3dB)	BW	kHz		400		No RC circuit
Output voltage noise	V_{noise}	mVpp		10		
DC ~ 10 kHz				15		
DC ~ 100 kHz						
Accuracy @ 25°C	X	% of I_{pn}	-1		1	@ 25°C
Accuracy @ $-40^\circ\text{C} \sim 105^\circ\text{C}$	X_{TRange}	% of I_{pn}	-2		2	$-40^\circ\text{C} \sim 105^\circ\text{C}$

10. STK-180PL/Z Electrical performance

Condition: $T_A = 25^\circ\text{C}$ $V_{cc} = 5\text{V}$ (Except special instructions)

Parameter	Symbol	Unit	Min	Typ	Max	Comment
Primary nominal current rms	I_{pn}	A		180		
Primary current measuring range	I_{pm}	A	-375		375	
Supply voltage	V_{cc}	V	4.75	5	5.25	
Current consumption	I_{cc}	mA		5	10	
Reference voltage	V_{ref}	V	2.48	2.5	2.52	Output function
Rated output voltage	V_{FS}	V		0.8		$(V_{out} - V_{ref}) @ I_{pn}$
Internal output resistance	R_{out}	Ω		1		Output
Quiescent voltage	V_{off}	V	2.48	2.5	2.52	$V_{out} @ 0\text{A}$
Electrical offset voltage	V_{oe}	mV	-10		10	$(V_{out} - V_{ref}) @ 0\text{A}$
Temperature drift of V_{oe}	V_{oe_TRange}	% V_{FS}	-1.5		1.5	$-40^\circ\text{C} \sim 105^\circ\text{C}$
Magnetic offset current	I_{om}	A	-0.25		0.25	@ $\pm 10 \times I_{pn}$
Theoretical gain	G_{th}	mV/A		4.44		800 mV @ I_{pn}
Error of gain	Err_G	% G_{th}		± 1		Trimmed in the factory @ 25°C
Temperature drift of gain	G_{TR}	% G_{th}	-1.0		1.0	$-40^\circ\text{C} \sim 105^\circ\text{C}$
Rated linearity error	$Non-L_{pn}$	% I_{pn}	-0.5		0.5	$\pm I_{pn}$
Linearity error @ I_{pm}	$Non-L_{pm}$	% I_{pm}	-3		3	$\pm I_{pm}$
Reaction time	t_{ra}	μs		0.4		@ 10% of I_{pn}
Step response time	t_{res}	μs		1.5		@ 90% of I_{pn}
Delay time	t_{delay}	μs		0.8		400 kHz sine wave
Frequency bandwidth (-3dB)	BW	kHz		400		No RC circuit
Output voltage noise	V_{noise}	mVpp				
DC ~ 10 kHz			10			
DC ~ 100 kHz	15					
Accuracy @ 25°C	X	% of I_{pn}	-1		1	@ 25°C
Accuracy @ $-40^\circ\text{C} \sim 105^\circ\text{C}$	X_{TRange}	% of I_{pn}	-2		2	$-40^\circ\text{C} \sim 105^\circ\text{C}$

11. Output voltage VS primary current

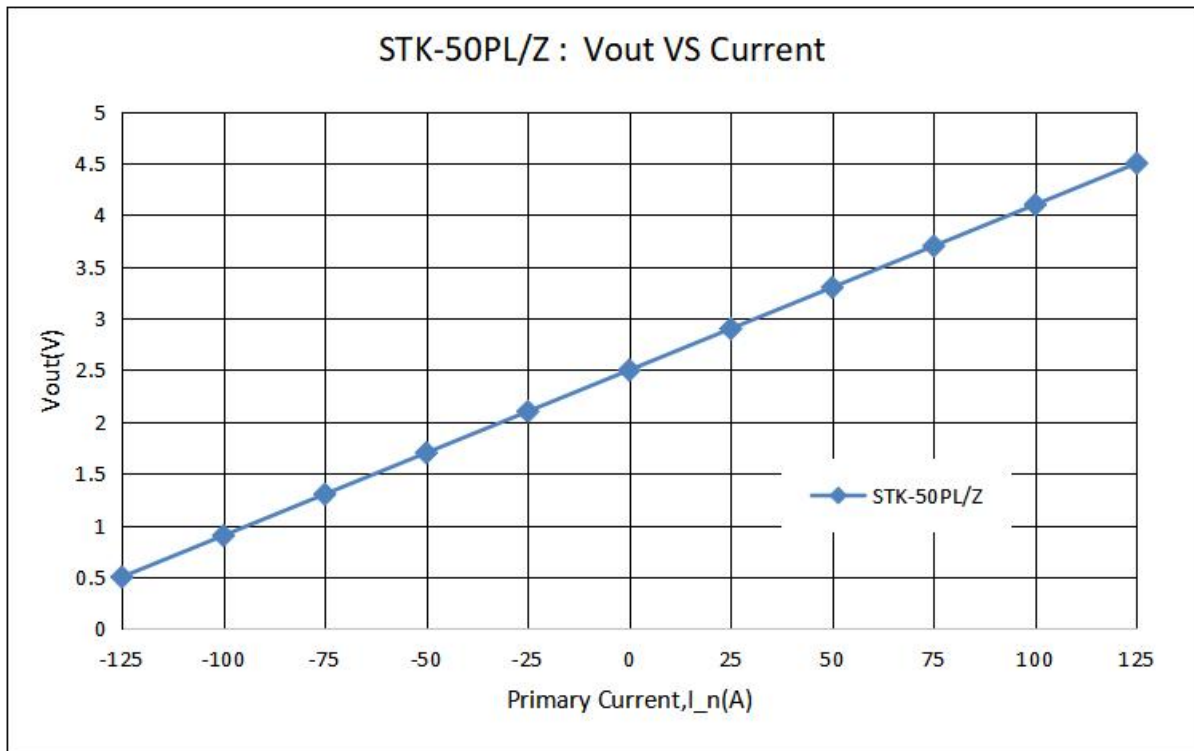

The dependence of Vout of STK-50PL/Z on the primary current.

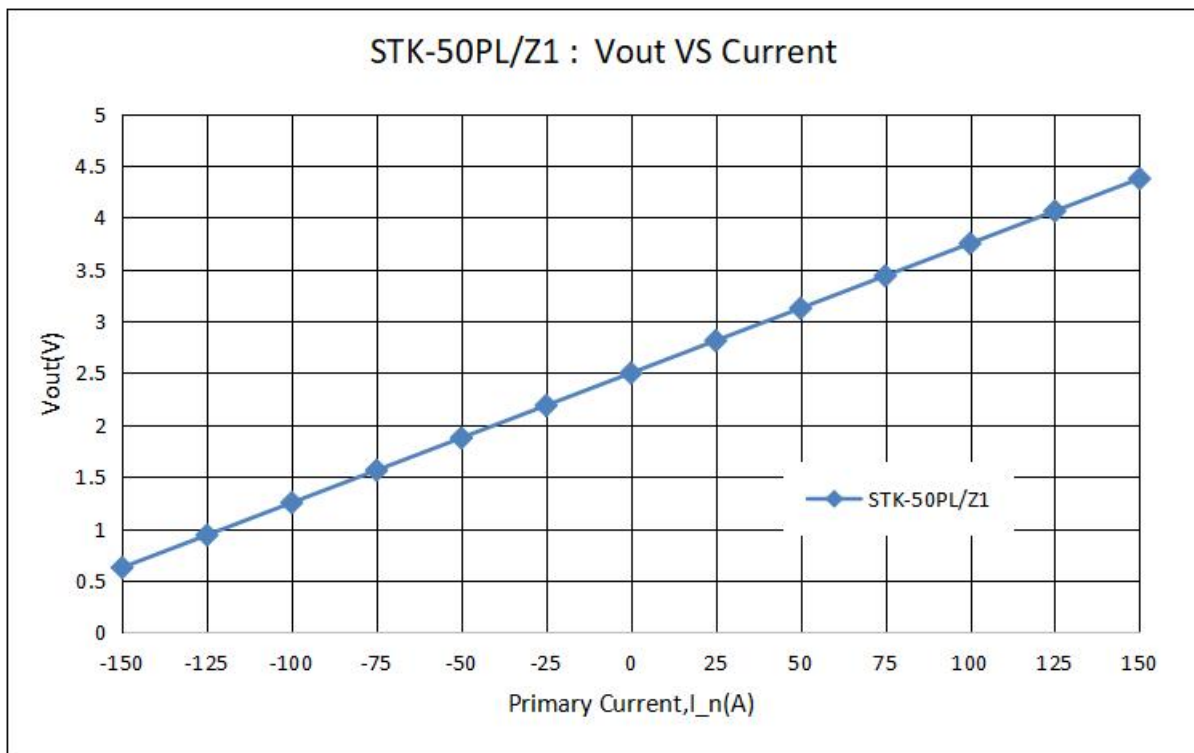

The dependence of Vout of STK-50PL/Z1 on the primary current.

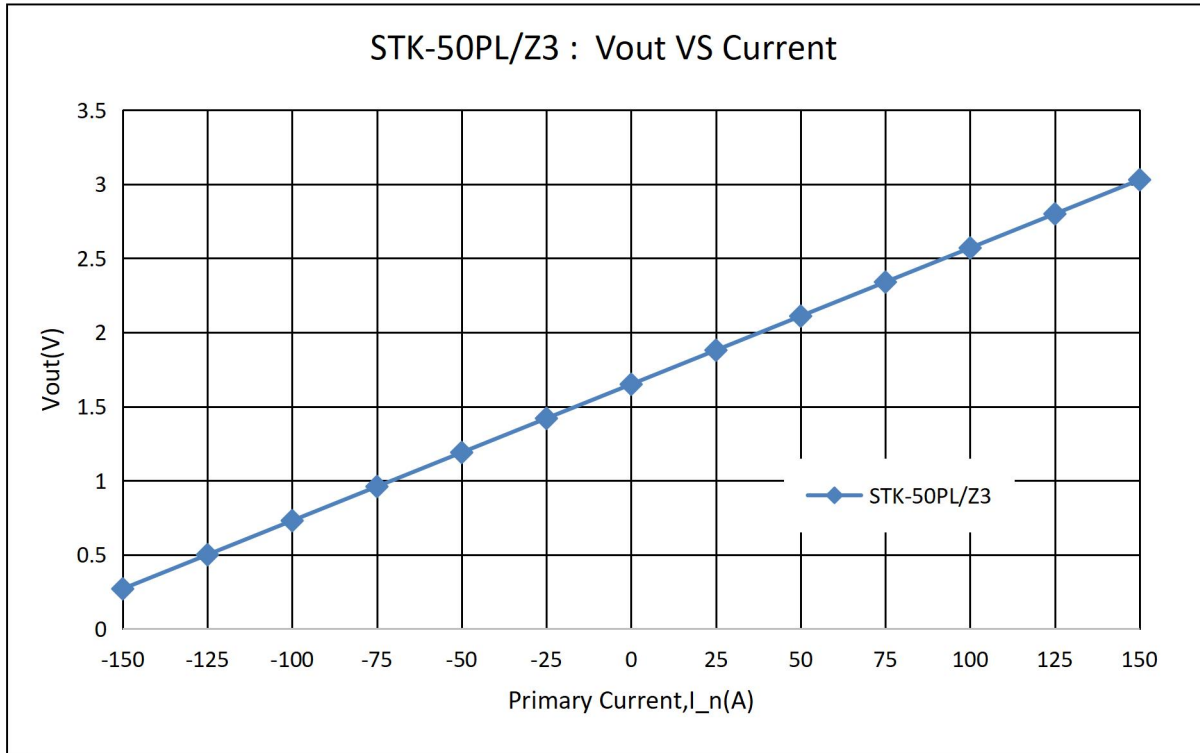

The dependence of Vout of STK-50PL/Z3 on the primary current.

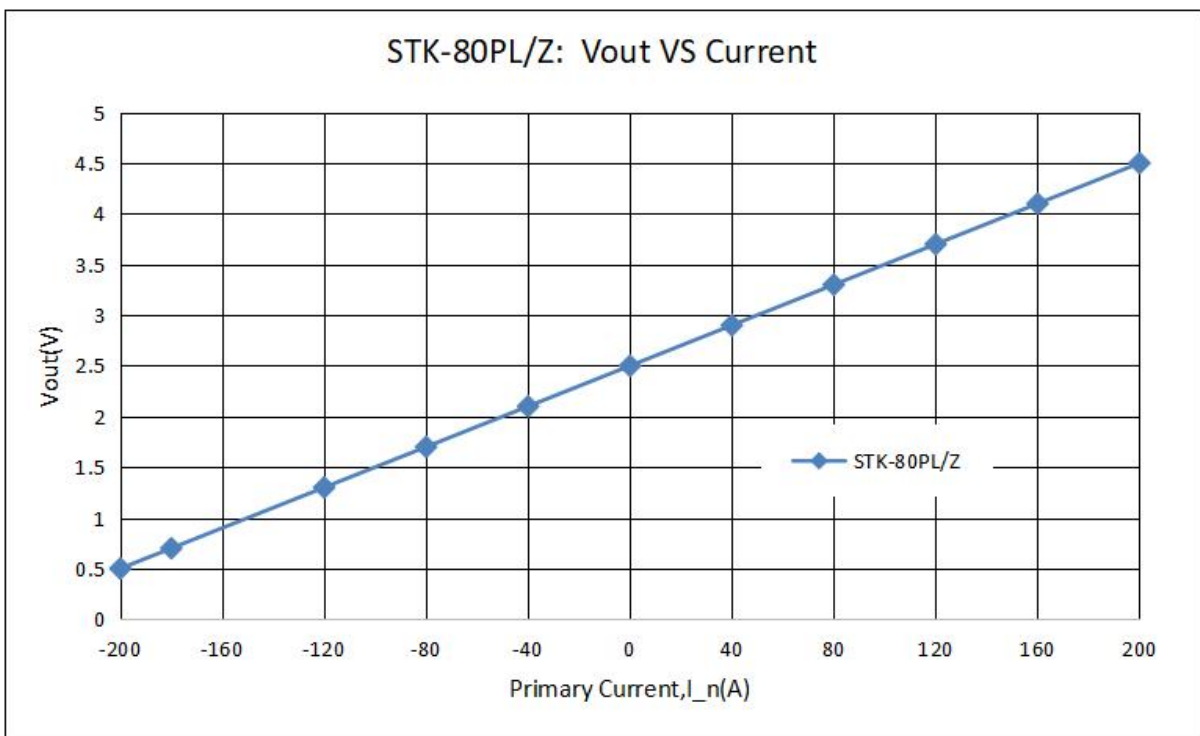

The dependence of Vout of STK-80PL/Z on the primary current.

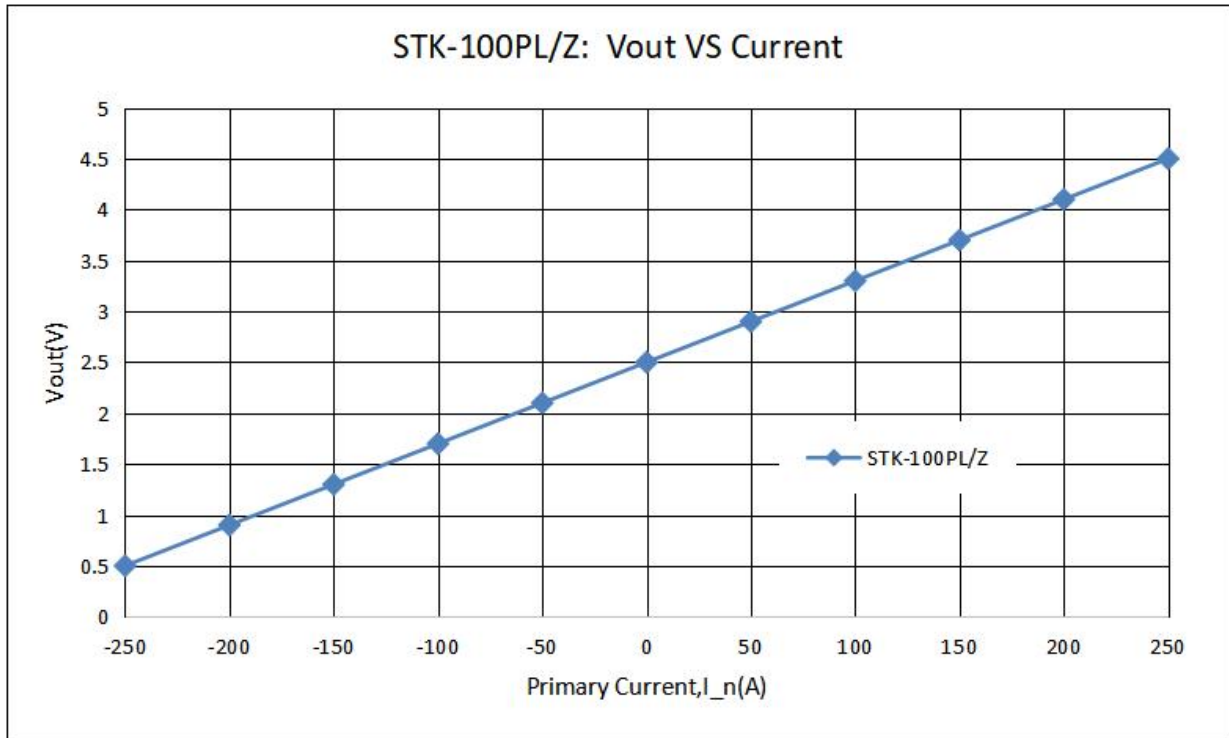

The dependence of Vout of STK-100PL/Z on the primary current.

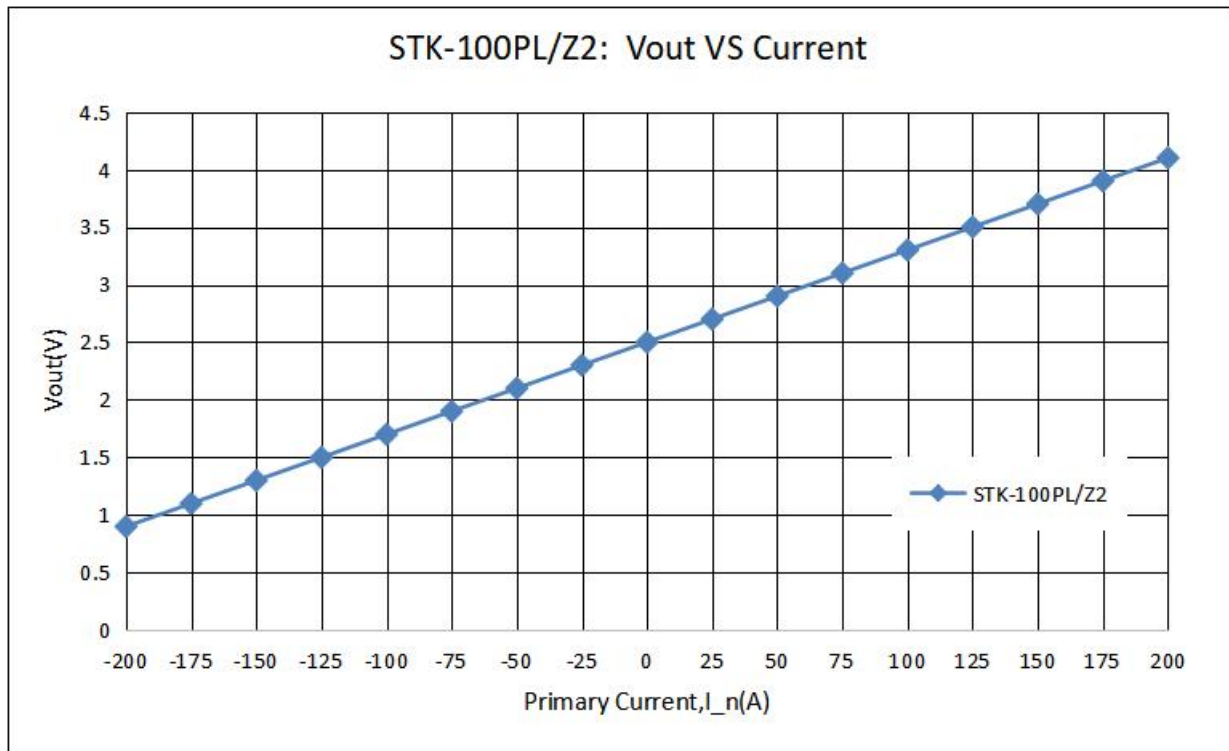

The dependence of Vout of STK-100PL/Z2 on the primary current.

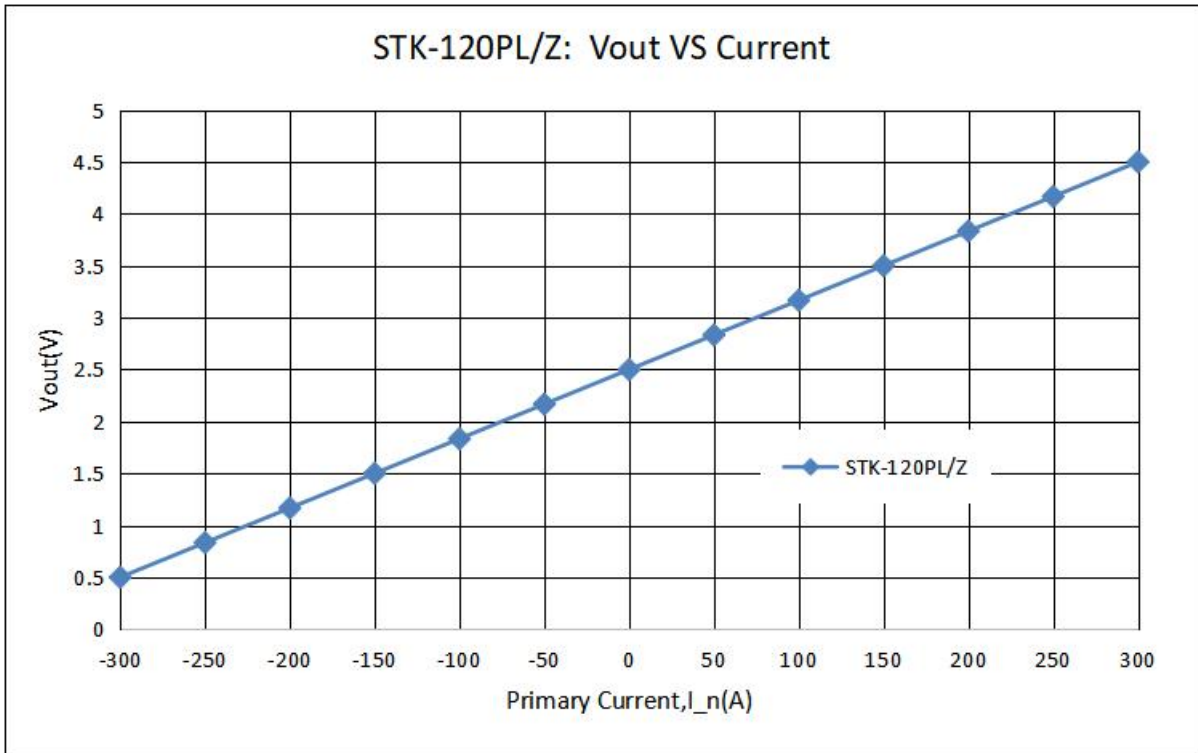

The dependence of Vout of STK-120PL/Z on the primary current.

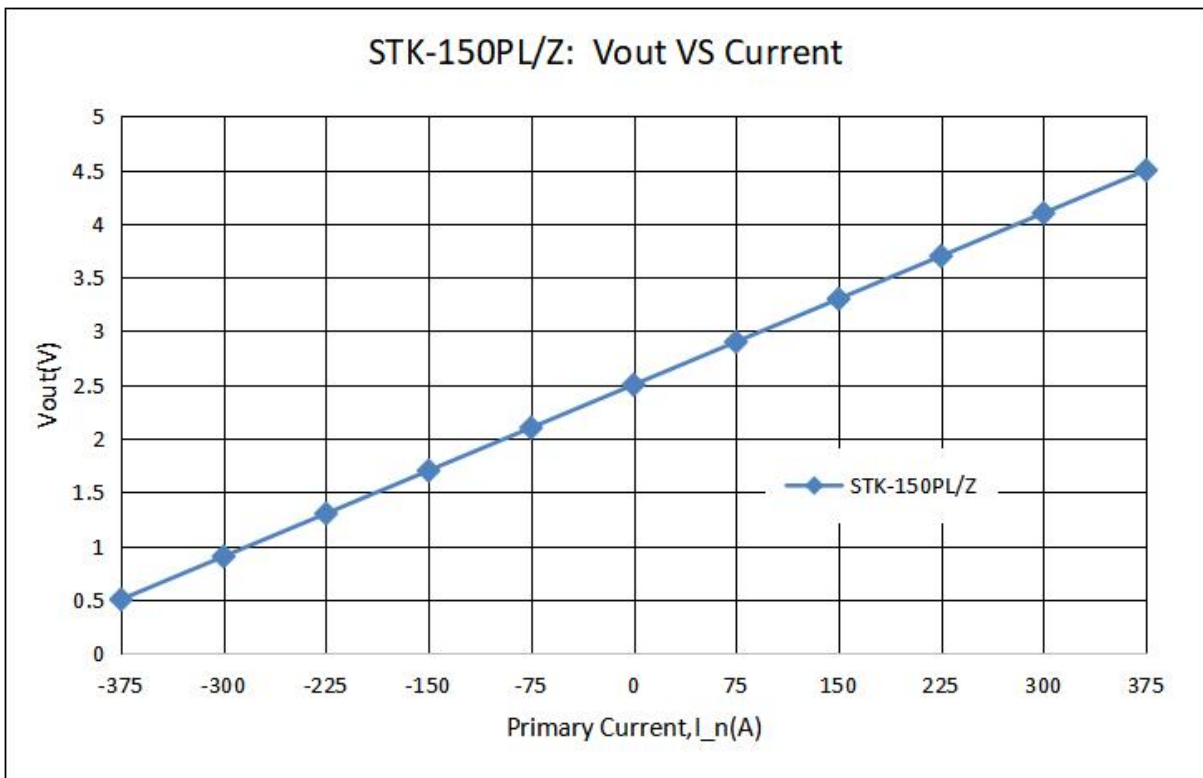

The dependence of Vout of STK-150PL/Z on the primary current.

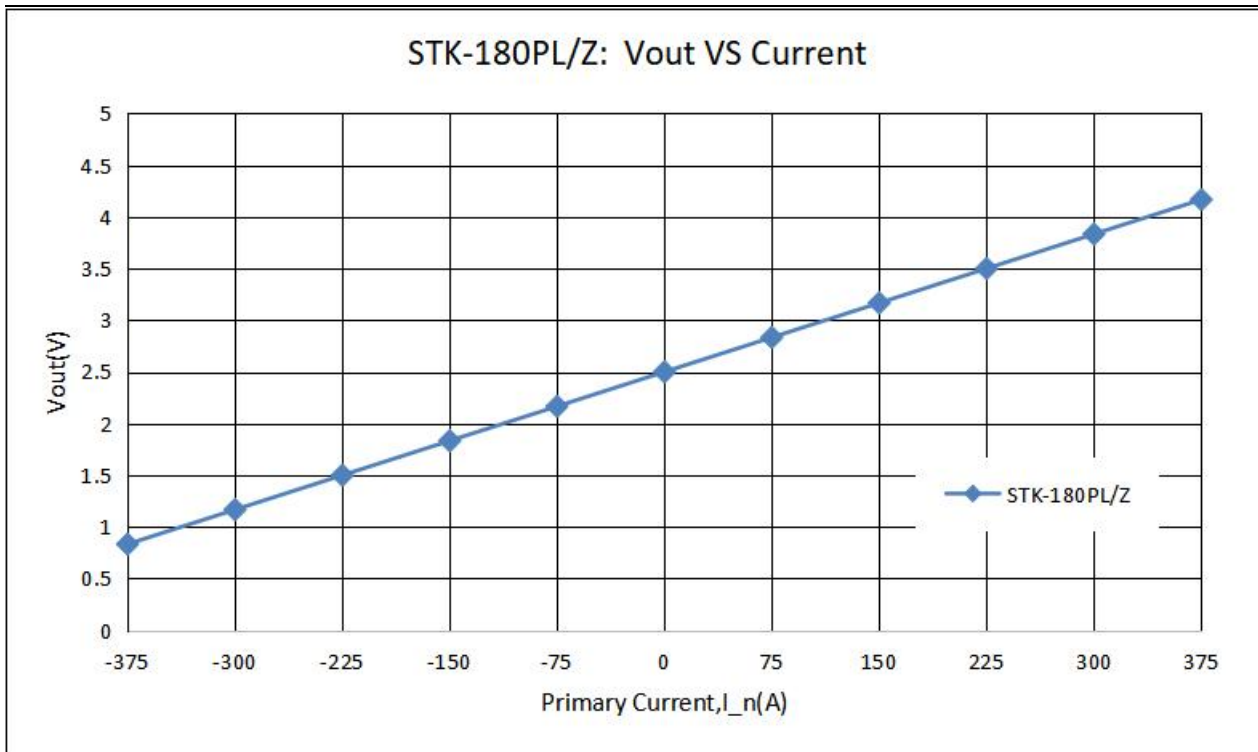

The dependence of Vout of STK-180PL/Z on the primary current.

12. Accuracy characteristics in room temperature

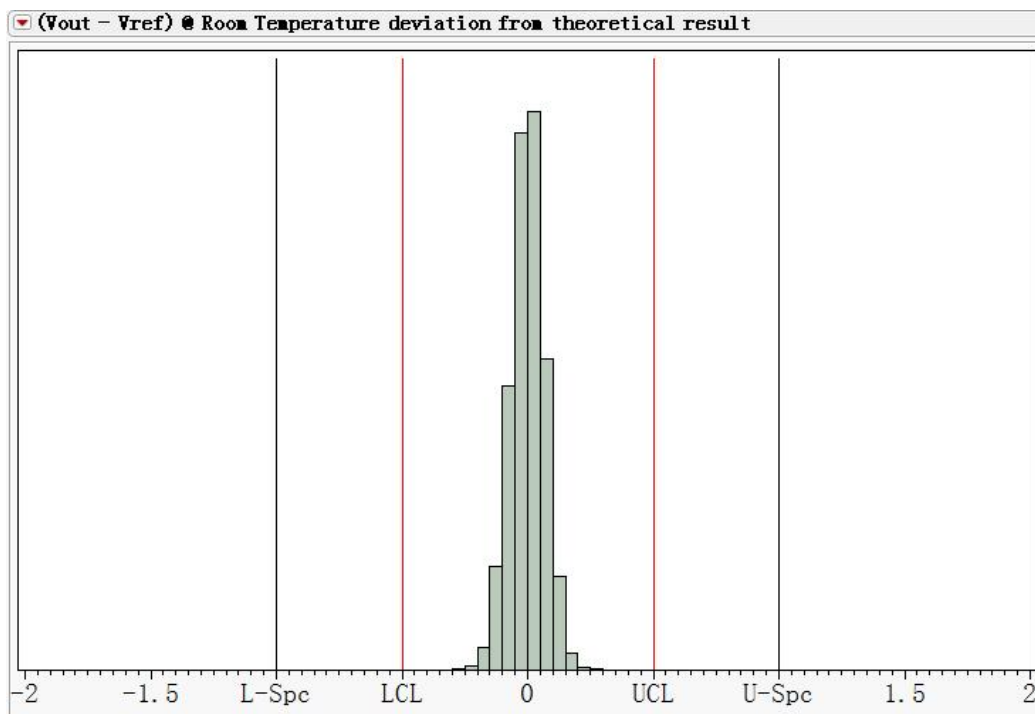

The error of STK-PL/Z current sensor at 25 °C compared with the standard output , $((V_{out} - V_{ref})_{measure} @ I_n @ 25^{\circ}C - V_{oe}@25^{\circ}C - G_{th} * I_n) / V_{FS}$. Vout represents voltage of Vout, Vref the voltage of Vref, I_n the primary current, V_{oe} the (Vout - Vref)_{@0A}, G_{th} the theoretical gain, V_{FS} the rated output voltage.

13. Accuracy cross temperature

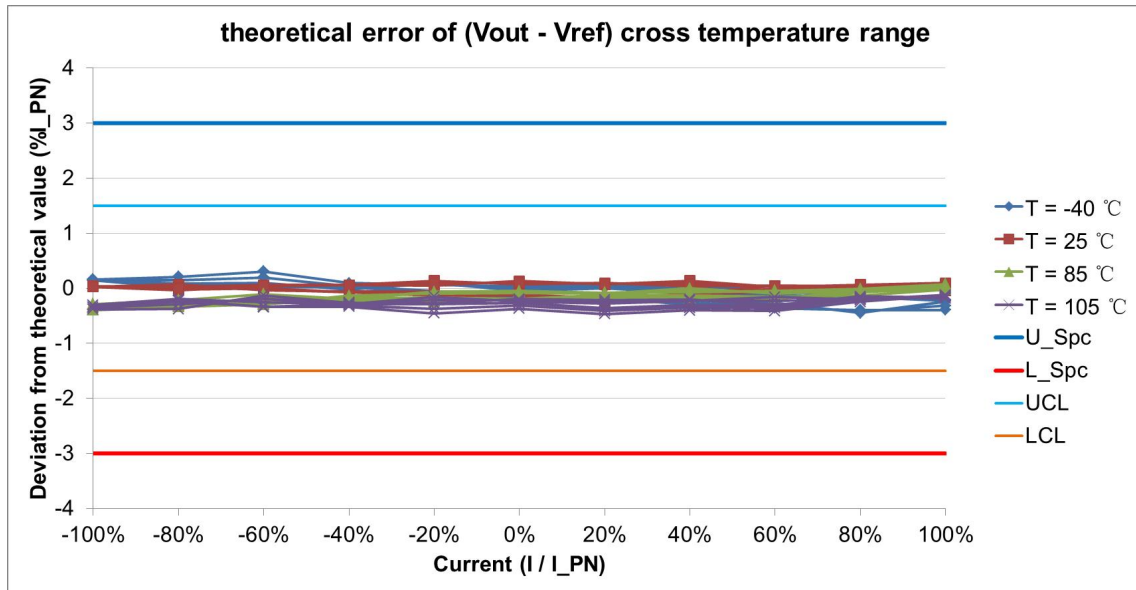

The error of STK-PL/Z current sensor at $-40^{\circ}\text{C} \sim 105^{\circ}\text{C}$ compared with the standard output at room temperature, $((V_{out} - V_{ref})_{measure} @ I_n @ T_x - V_{oe} @ T_x - G_{th} * I_n) / V_{FS}$. Where, V_{out} represents voltage of V_{out} , V_{ref} the voltage of V_{ref} , I_n the primary current, T_x the present temperature, V_{oe} the $(V_{out} - V_{ref}) @ 0A$, G_{th} the theoretical gain, V_{FS} the rated output voltage.

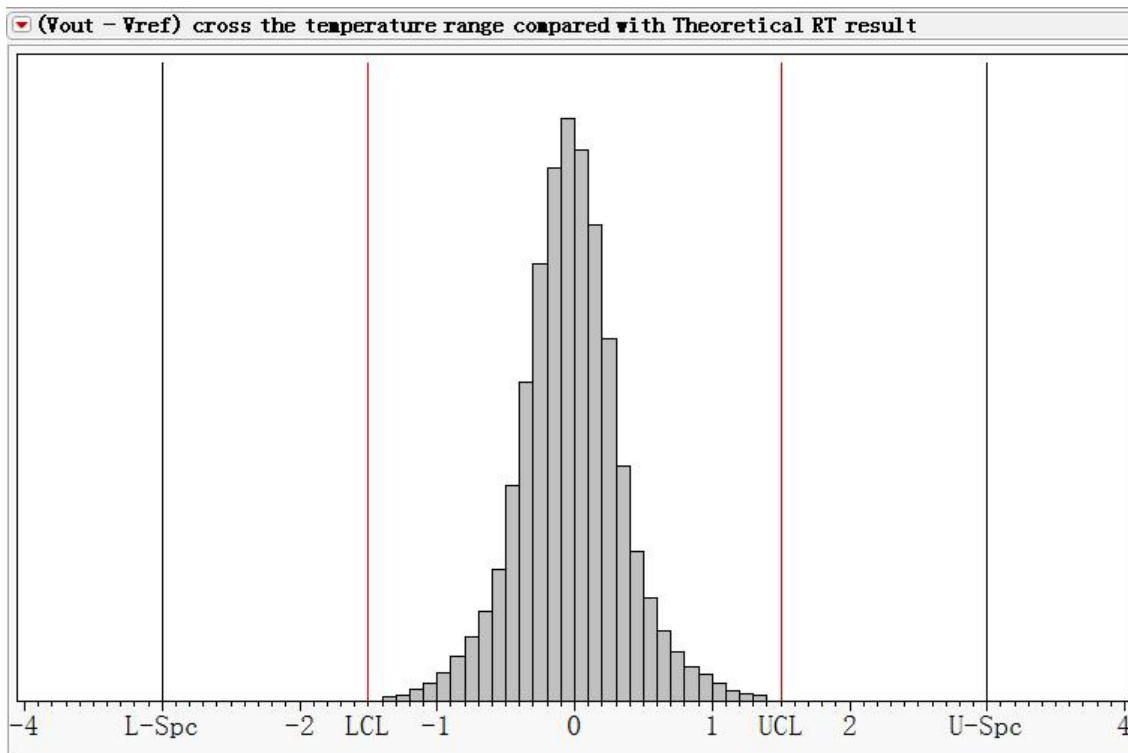

The error of STK-PL/Z output $(V_{out} - V_{ref})$ current sensor at $-40^{\circ}\text{C} \sim 105^{\circ}\text{C}$ compared with the standard output $(V = G_{th} * I_n)$, $((V_{out} - V_{ref}) @ I_n @ T_x - G_{th} * I_n) / V_{FS}$, Where, I_n represents present primary current, T_x the present temperature, G_{th} the theoretical gain, V_{FS} the rated output voltage.

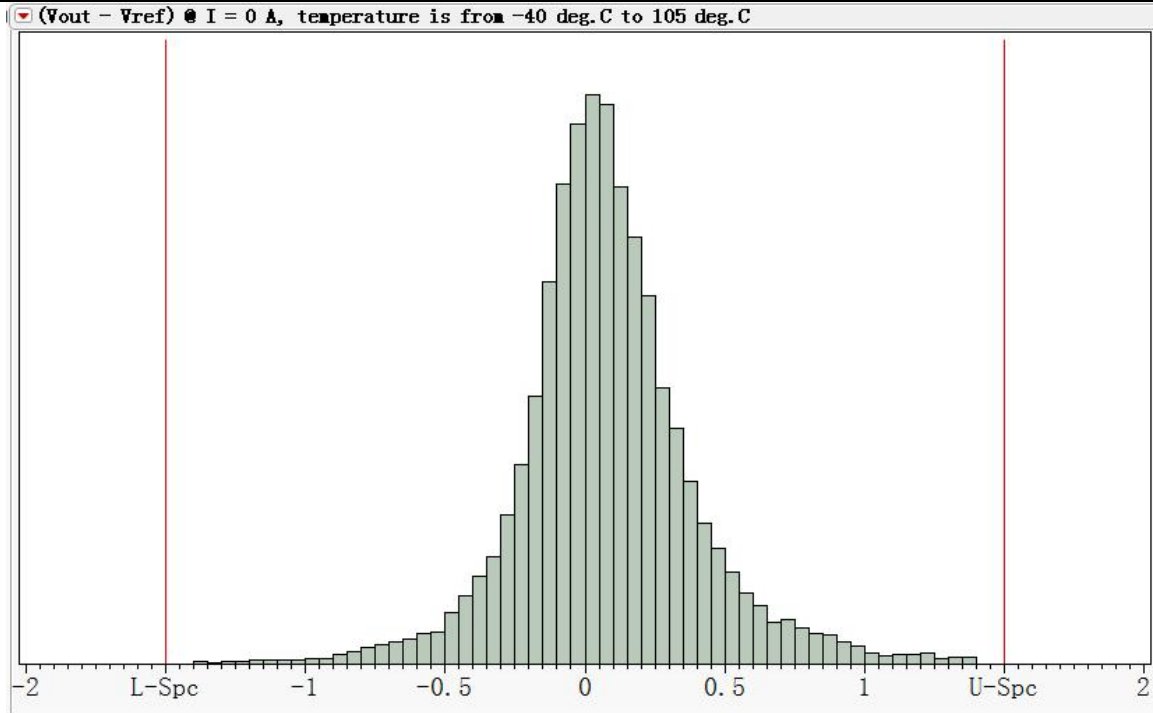

Temperature drift of Voe, $V_{oe_TRange} = (V_{oe} @ T_x - V_{oe} @ 25^{\circ}C) / V_{FS}$. T_x represents present temperature, V_{FS} the rated output voltage.

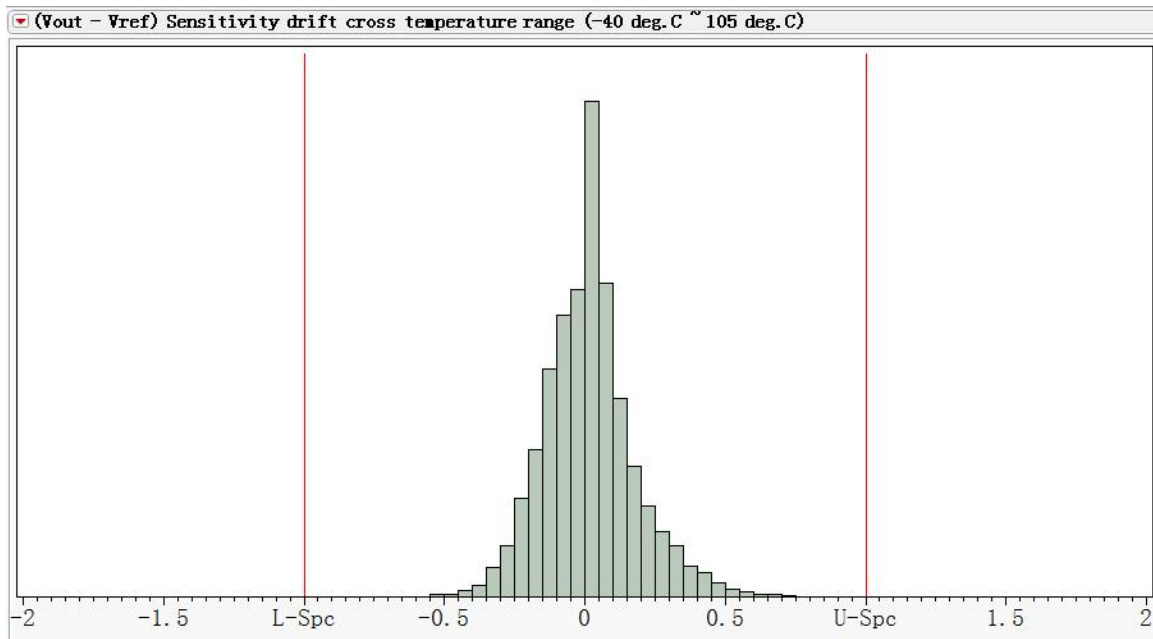

Error of gain, $Err_G = (((V_{out} - V_{ref}) @ I_{pn} - (V_{out} - V_{ref}) @ (-I_{pn})) / 2) - V_{FS} / V_{FS}$. Where I_{pn} represents the rated current, $-I_{pn}$ the reversed rated current.

14. Frequency response and bandwidth

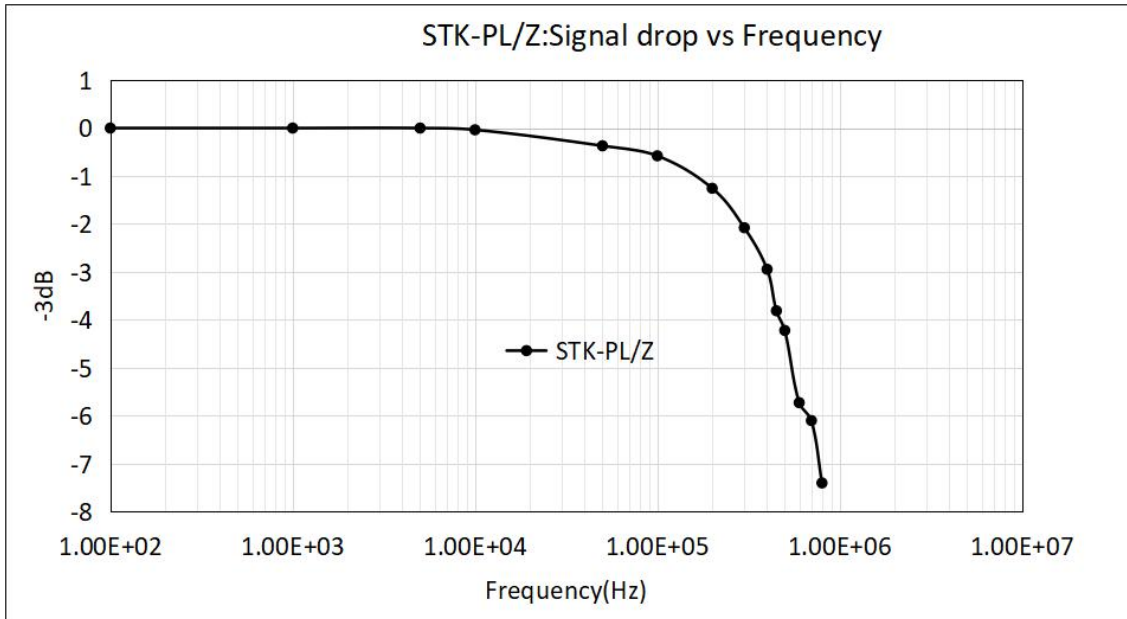

The frequency bandwidth of STK-xxPL/Z series current sensor. The bandwidth of current sensor is DC ~ 400 kHz (-3dB).

15. Step response time

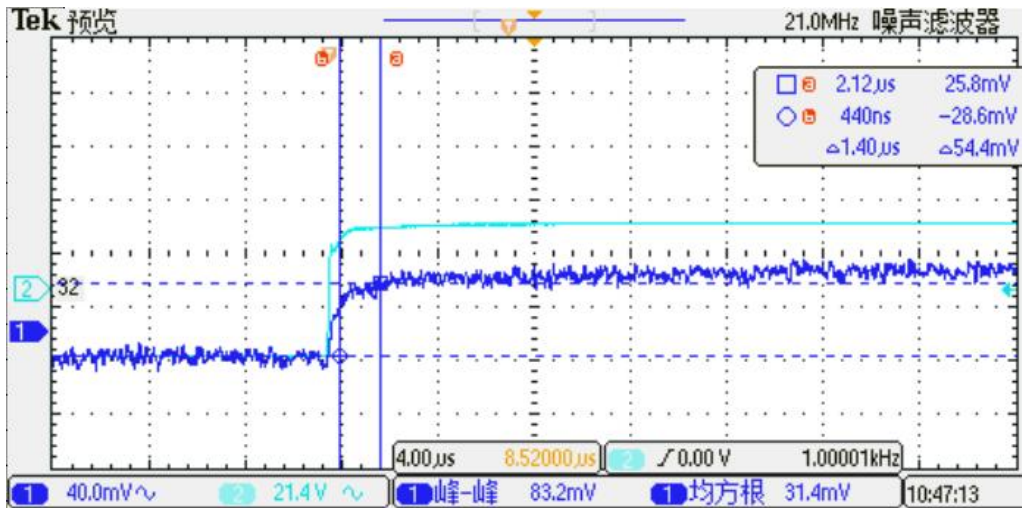

The typical frequency response of STK-xxPL/Z current sensor. The response time from 90% of the primary current (light blue) to 90% of the secondary output (dark blue) is less than 1.5 µs

16. Frequency delay performance

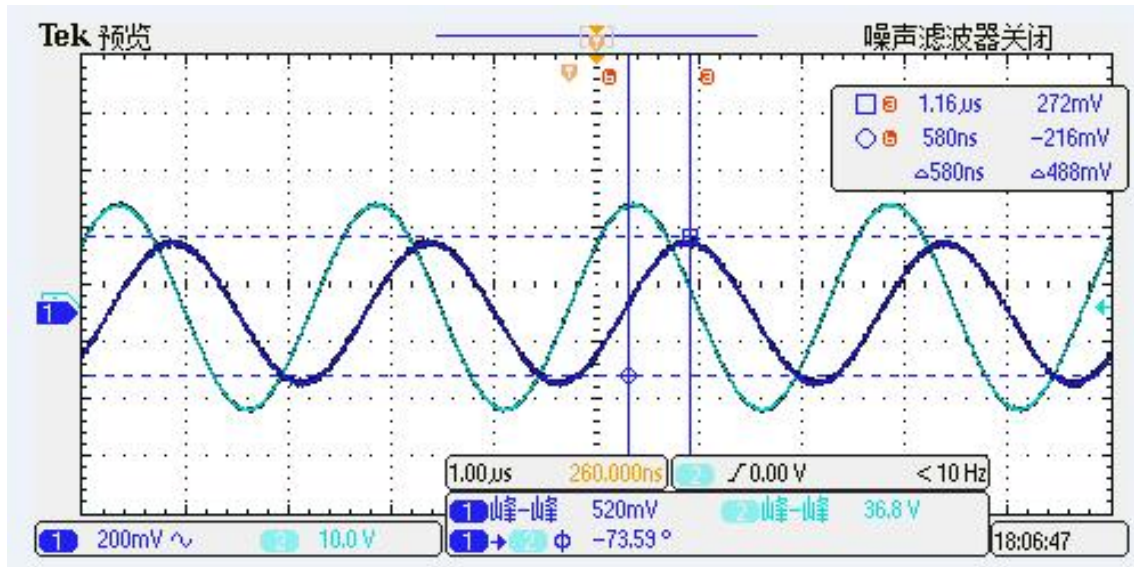

When testing 400 kHz sine wave, the typical result of STK-xxPL/Z current sensor's output. The response time from the primary current (light blue) to the secondary output (dark blue) is less than 0.8μ s.

17. Recommended PCB layout

Installation of view: overlooking (unit: mm)

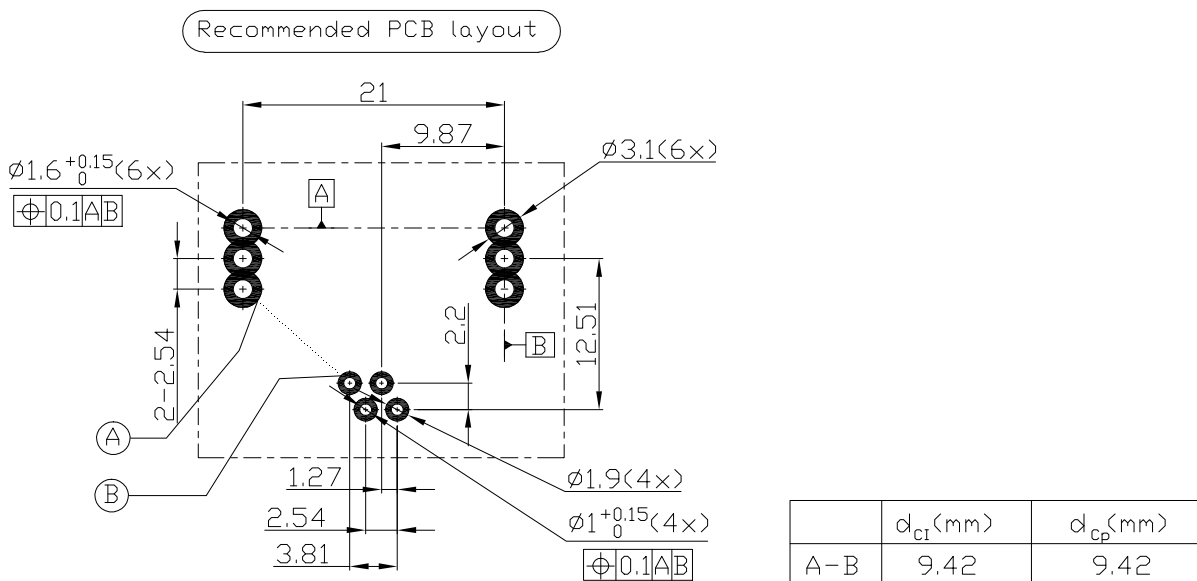

1. Installing angle: Overlook (observe from the side of installing transducer)
2. Recommended bore diameter of primary current line, (diameter of primary current $\times 1.2$) mm
3. Recommended bore diameter of secondary current line, (diameter of secondary current $\times 1.2$) mm
4. The maximum thickness of PCB is 2.5 mm
5. The curve of wave soldering: $260^{\circ}\text{C} \times 10 \text{ s}$



Security:

This current sensor must be used in limited-energy secondary circuit according to IEC 61010-1.

- This current sensor must be used in electric/electronic equipment with respect to appliance standards and safety requirement in accordance with the manufacture's operating instructions;
- When operating the current sensor, certain parts of the module can carry hazardous voltage;
- Failure to wiring as shown in the diagram will damage the current sensor;
- Ignoring this warning can lead to serious consequences.
- A protective housing or a additional shield could be used.
- Main supply must be able to disconnected.

18. Dimension & Pin definitions

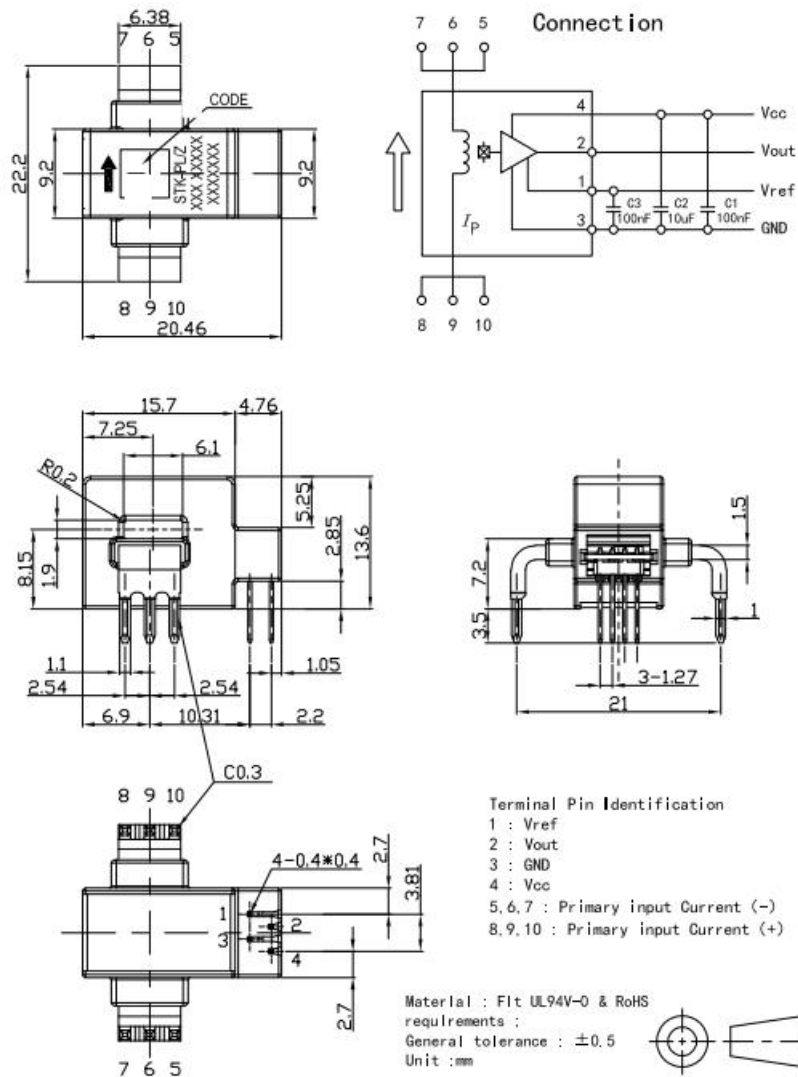

19. Appendix: typical application circuit

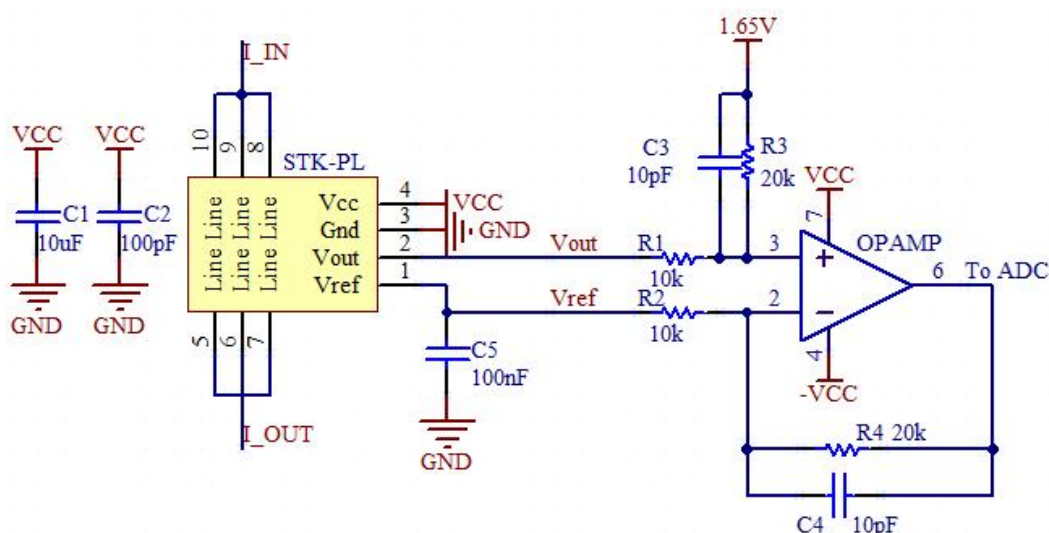
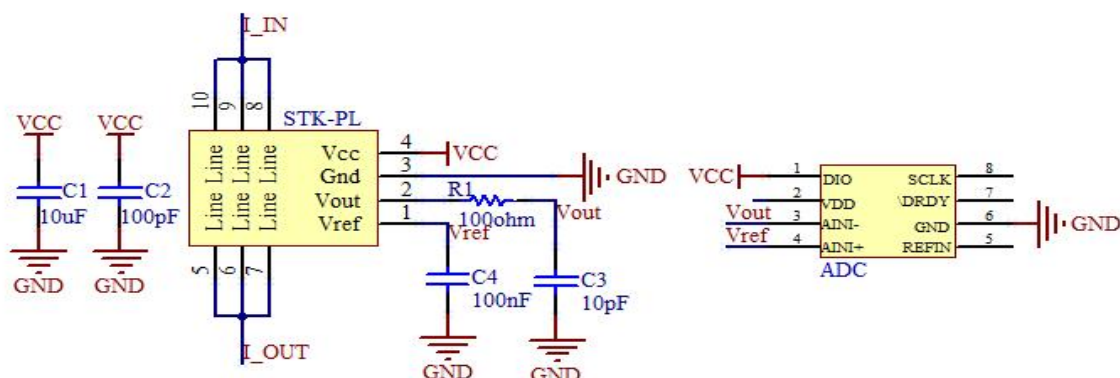

R3 (kohm)	C3 (pF)	Theoretical -3dB $f = 1/(2\pi RC)$ (kHz)	Measured -3dB (kHz)
20	20	398	~400
20	81	98	~ 100
20	810	10	~ 10

The frequency characteristics of STK-xxPL/Z series current sensor are not affected by the R-C setting (according to recommended R-C setting), therefore the active filter circuit or R-C circuit can be applied to modulate the sensor's frequency characteristics.

The signal input to ADC is $1.65 + R4/R2 * (Vout - Vref)$ with the conditions: $R1 = R2, R3 = R4, C3 = C4$.