

CURRENT SENSOR

PRODUCT SERIES: STB-CAB1000

PRODUCT PART NUMBER: STB-CAB1000N-x

VERSION: Ver 2.0.1



Sinomags Technology Co., Ltd.

Web site: www.sinomags.com

CONTENT

1. Characteristic	2
2. General parameters	2
3. Electrical parameters	3
4. Total Error Graph for CAB-1000	3
5. CAB-1000 CAN Output specification.....	4
6. Diagnostic Trouble Code (DTC).....	4
7. Dimensions: (in mm)	5
8. Application	5
9. Product definition statement	6

1. Characteristic

CAB1000 Series current sensor is based on Sinomags Active Close Loop technology, with CANBUS digital output. It can be used to measure 1000A rated current. Using a proprietary Digital Compensation technology. This product brings the best combination of performance and reliability.

- ALL temperature Error $\pm 0.3A$ @ $\pm < 50A$, Sensitivity error Accuracy $\pm 0.5\%$ @ $\geq \pm 50-1000A$.
- High electromagnetic compatibility against complex electromagnetic interference environment.
- Excellent anti magnetic interference.
- CANBUS output, convenient for system integration.
- Ultra-high over current capability

2. General parameters

Working temperature: $-40^{\circ}C \sim +85^{\circ}C$;
Insulation resistance: $\geq 500 M\Omega$;
Rms voltage for AC insulation test 50Hz 1min 2.5KV
Over-voltage 24V/1 minute
Electrostatic discharge voltage 13KV

3. Electrical parameters

Parameter	Symbol	Unit	Specification			Conditions
			Min	Type	Max	
Nominal Measuring Range	I_{PN}	A	-1000		1000	
Supply Voltage	U_C	V	9.2	12	18	Full accuracy
Current Consumption @ $I_P=0A$	I_C	mA		40		$U_C=12V, T=25^\circ C$
Current Consumption @ $I_P=1000A$	I_C	mA		400		$U_C=12V, T=25^\circ C$
Sensitivity error Accuracy	X_G	%	-0.5		0.5	$=-40$ to $85^\circ C$; ± 3 sigma ($> \pm 50A$)
Offset=0A	I_{OS}	A		± 0.3		$=-40$ to $85^\circ C$; ± 3 sigma
Linearity error with I_{PN}	ϵ_L	%		0.1		@room temperature
Temperature coefficient of G	TCG	ppm/ $^\circ C$		20		
Creepage distance	d_{CP}	mm		52		Centre bore
Electric clearance	d_{CI}	mm		48		Centre bore

4. Total Error Graph for CAB-1000

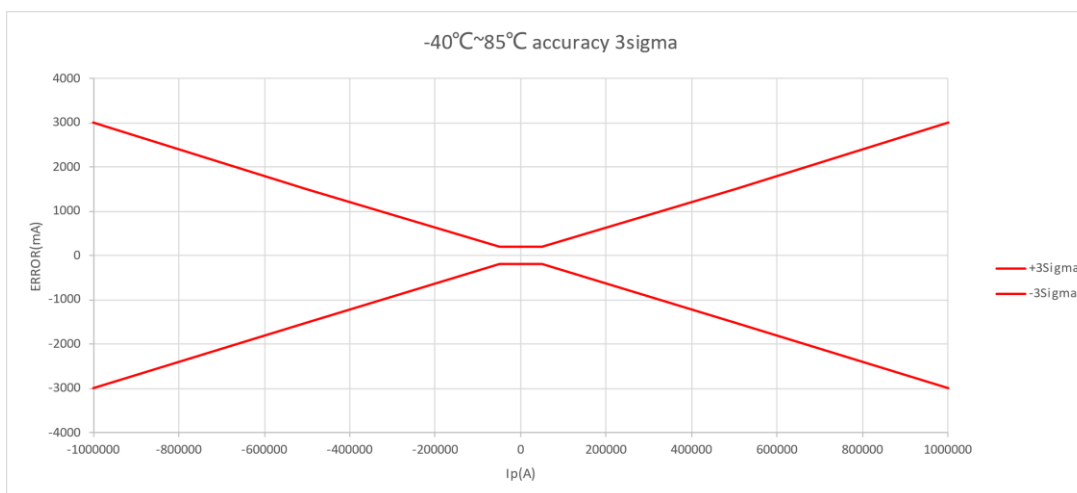

5. CAB-1000 CAN Output specification

CANBUS speed refer to product version table

CANBUS protocol: version 2.0A/B

CAN oscillator tolerance: 0.3125%

Byte order: big endian (Motorola)

120 ohm termination resistor to be added externally, internal CAN impedance = 4.8Kohm

Message Description	CAN ID	name	Data Length (bytes)	Type of frame	Message launch type	Signal description	Signal Name	Start bit	End bit	
Current Ip (mA)	0x3C1	CAB1000	8	stand	ard	Cyclic message every 10ms	Ip Value: 80000000H= 0mA, 7FFFFFFFH= - 1mA, 80000001H= 1mA	IP_VALUE	0	31
							b0-b6:Error information	ERROR_INFORMATION	32	38
							b7:Error indication	ERROR_INDICATION	39	39
							Ip Maximum: 80000H=0mA 7FFFFFFH=-1mA 800001H=1mA	MAX_CURRENT_VALUE	40	63

6. Diagnostic Trouble Code (DTC)

FAILLURE MODE	Ip VALUE	ERROR INDICATION	ERROR INFORMATION
Overcurrent Detection Ip> Approximate 1050A	FFFFFFFF	1	0x41
Closed-loop reference voltage over range	FFFFFFFF	1	0x42
Signal not available for more than 100ms	FFFFFFFF	1	0x44
Supply voltage out of range	FFFFFFFF	1	0x46

7. Dimensions: (in mm)

Connector type: TYCO 1473672-1

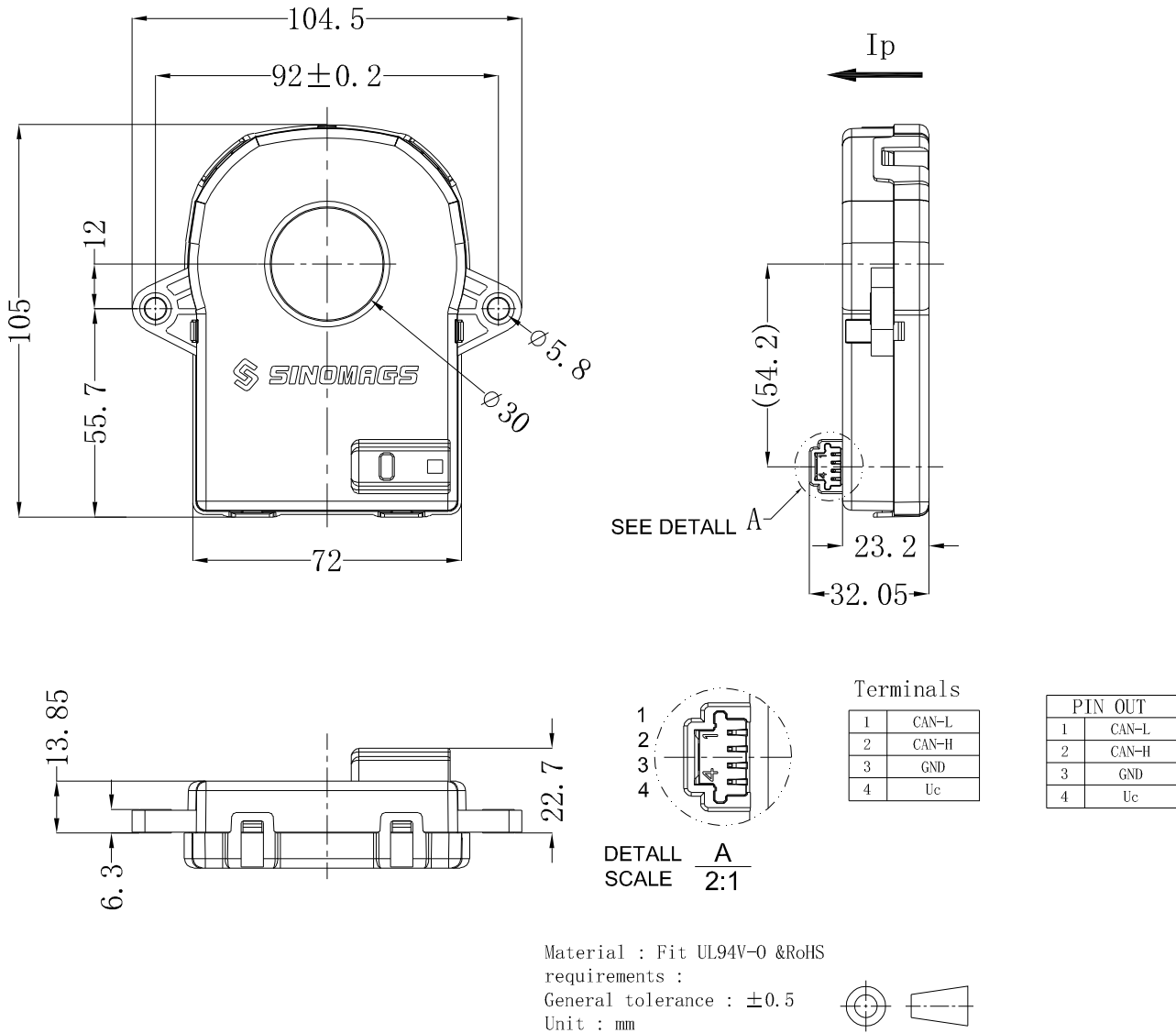

Mechanical characteristics

1. Unspecified tolerance: $\pm 0.5\text{mm}$
2. Plastic housing material: PA66 +GF30%
3. Mounting screw M5, torque max 3 Nm
4. Mass: $192\text{g} \pm 5\text{g}$
5. Contacts: Matte-tin 3.0um min 5.0um max on solder tail, with entire contact underplated 4.0um min 5.0um max, Nickel-palladium alloy

8. Application

- Accurate current measurement for battery management applications

9. Product definition statement

