

Current Sensor

Product Series: STK-PL/Z3

Part number: STK-50PL/Z3

Version: Ver1.1

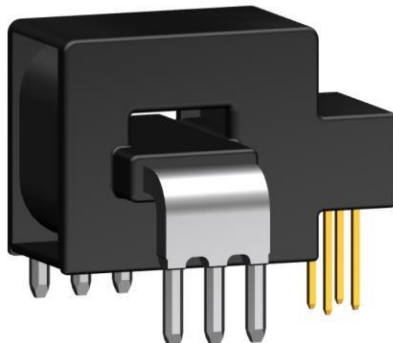

Sinomags Technology Co., Ltd

Web site: www.sinomags.com

CONTENT

1. Summary.....	2
2. STK-50PL/Z3 Electrical performance.....	4
3. Output voltage VS primary current	5
4. Temperature derating curve	5
5. Accuracy characteristics in room temperature.....	6
6. Accuracy cross temperature	6
7. Frequency response and bandwidth	8
8. Step response time	9
9. Frequency delay performance.....	9
10. Recommended PCB layout	10
11. Dimension & Pin definitions.....	11
12. Appendix: typical application circuit.....	12

1. Summary

The STK-PL/Z3 series is based on open-loop technology and design. It is suitable for DC, AC, pulse and any type of irregular current measurement under isolated conditions. The nominal current range of STK-PL/Z3 current sensors includes 50A.

Typical applications

- PV combiner box
- PV inverter (MPPT & AC)
- motor driver controller
- SMPS & UPS
- Battery management system

Standards

- EN50178:1997
- IEC 61010-1:2010
- IEC 61326-1:2012

General parameter

Parameter	Symbol	Unit	Value
Working temperature	T _A	°C	-40 ~ 105
Storage temperature	T _{stg}	°C	-40 ~ 105
Mass	m	g	10

Absolute maximum rating

Parameter	Symbol	Unit	Value
Supply voltage (non-destructive)	V _C	V	6.0
ESD rating (HBM)	U _{ESD}	kV	4
ESD rating (CDM)	U _{CDM}	kV	1.5

Remark: the unrecoverable damage may occur when the product works on the conditions over the absolute maximum ratings. Long-time working on the absolute maximum ratings may cause the degradation on performance and reliability.

Ratings

Parameter	Symbol	Unit	Value
Primary involved potential		V AC/DC	600
Ambient operating temperature	T_A	°C	105
Primary current	I_p	A	According to series primary current
Secondary supply voltage	U_c	V DC	5
Output voltage	V_out	V	0.1 ~ 4.9

Isolation parameter

Parameter	Symbol	Unit	Value	Comment
RMS voltage for AC test 50Hz/1 min	U _d	kV	5	
Impulse withstand voltage 1.2/50μs	Ū _w	kV	8	
Clearance distance (pri. -sec)	d _{Cl}	mm	8	Shortest distance through air
Creepage distance (pri. -sec)	d _{Cp}	mm	8	Shortest path along device body
Case material			V0 according to UL 94	
Application example		V	600	Reinforced insulation, CAT III, PD 2, non uniform field according EN 50178, IEC 61010
Application example		V	1000	Basic insulation, CAT III, PD 2, non uniform field according EN 50178, IEC 61010
Application example		V	1500	Basic insulation, CAT III, PD 2, according to IEC 62109-1 Altitude ≤ 3000 m
Application example		V	600	CAT III, PD 2, according to UL 508

2. STK-50PL/Z3 Electrical performance

Condition: $T_A = 25^\circ\text{C}$ $V_{cc} = 3.3\text{ V}$ (Except special instructions)

Parameter	Symbol	Unit	Min	Typ	Max	Comment
Primary nominal current rms	I_{pn}	A		50		
Primary current measuring range	I_{pm}	A	-150		150	
Supply voltage	V_{cc}	V	3.135	3.3	3.465	
Current consumption	I_{cc}	mA		5	10	
Reference voltage	V_{ref}	V	1.63	1.65	1.67	Output function
Rated output voltage`	V_{FS}	V		0.46		$V_{out} - V_{ref} @ I_{pn}$
Internal output resistance	R_{out}	Ω		1		$V_{out} @ 0\text{ A}$
Quiescent voltage	V_{off}	V	1.63	1.65	1.67	$V_{out} @ 0\text{ A}$
Electrical offset voltage	V_{oe}	mV	-10		10	$(V_{out} - V_{ref}) @ 0\text{ A}$
Temperature drift of V_{oe}	V_{oe_TRange}	% V_{FS}	-1.5		1.5	$-40^\circ\text{C} \sim 105^\circ\text{C}$
Magnetic offset current	I_{om}	A	-0.25		0.25	@ $\pm 10 \times I_{pn}$
Theoretical gain	G_{th}	mV/A		9.2		460 mV @ I_{pn}
Error of gain	Err_G	% G_{th}	-0.5		0.5	Trimmed in the factory @ 25°C
Temperature drift of gain	Err_G_TRange	% V_{FS}	-1.0		1.0	$-40^\circ\text{C} \sim 105^\circ\text{C}$
Rated linearity error	Non-L	% I_{pn}	-0.5		0.5	$\pm I_{pn}$
Linearity error @ I_{pm}	Non-L	% I_{pm}	-3		3	$\pm I_{pm}$
Reaction time	t_{ra}	μs		0.4		@ 10% of I_{pn}
Step response time	t_{res}	μs		1.5		@ 90% of I_{pn}
Delay time	t_{delay}	μs		0.8		400 kHz sine wave
Frequency bandwidth (-3dB)	BW	kHz		400		No RC circuit
Output voltage noise DC ~ 10 kHz DC ~ 100 kHz	V_{noise}	mVpp		10 15		
Accuracy @ 25°C	X	% of I_{pn}	-1		1	@ 25°C
Accuracy @ $-40^\circ\text{C} \sim 105^\circ\text{C}$	X_TRange	% of I_{pn}	-3		3	$-40^\circ\text{C} \sim 105^\circ\text{C}$

3. Output voltage VS primary current

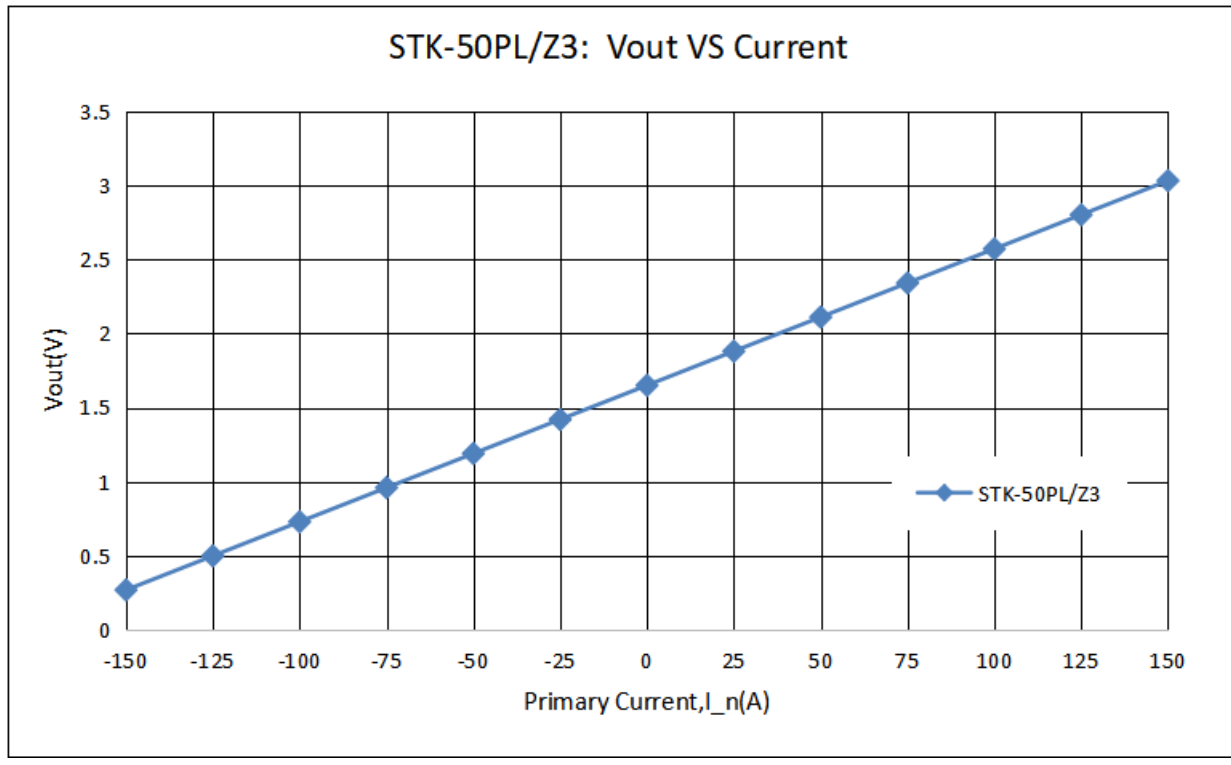

The dependence of Vout of STK-50PL/Z3 on the primary current.

4. Temperature derating curve

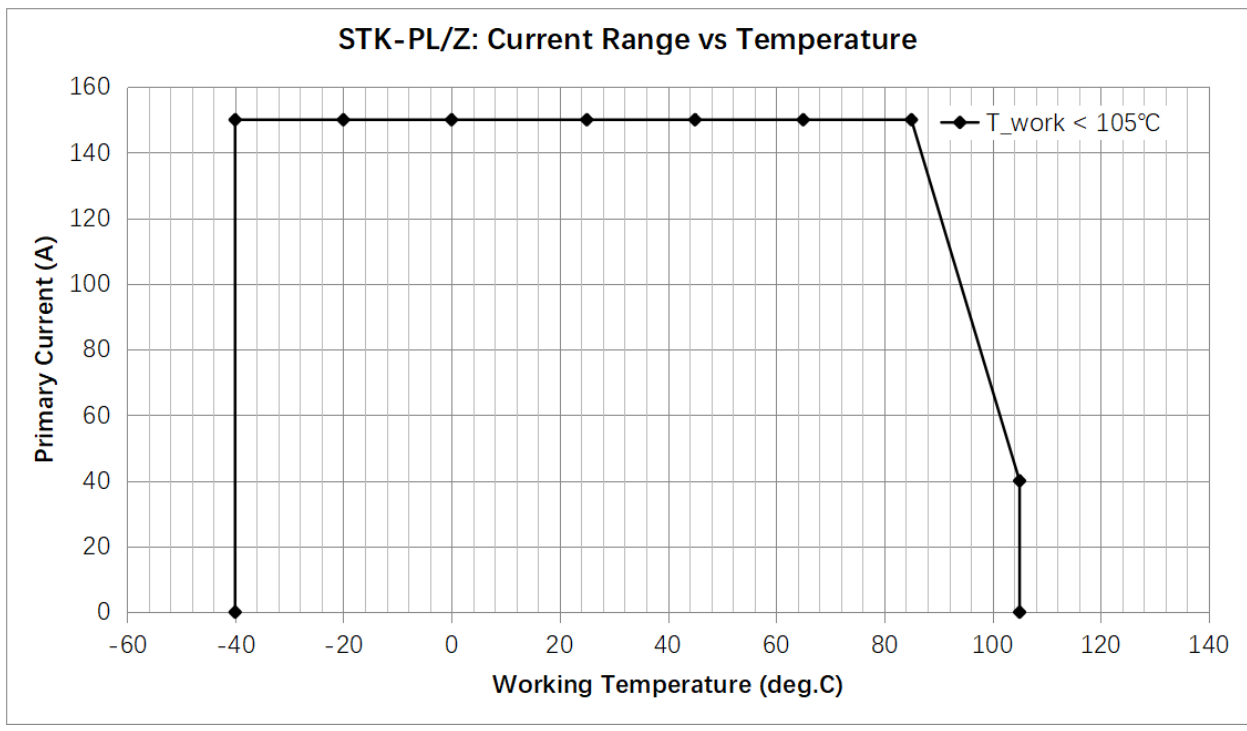

STK-PL/Z3 Temperature Derating Curve for Operating Temperatures Less Than 105°C.

5. Accuracy characteristics in room temperature

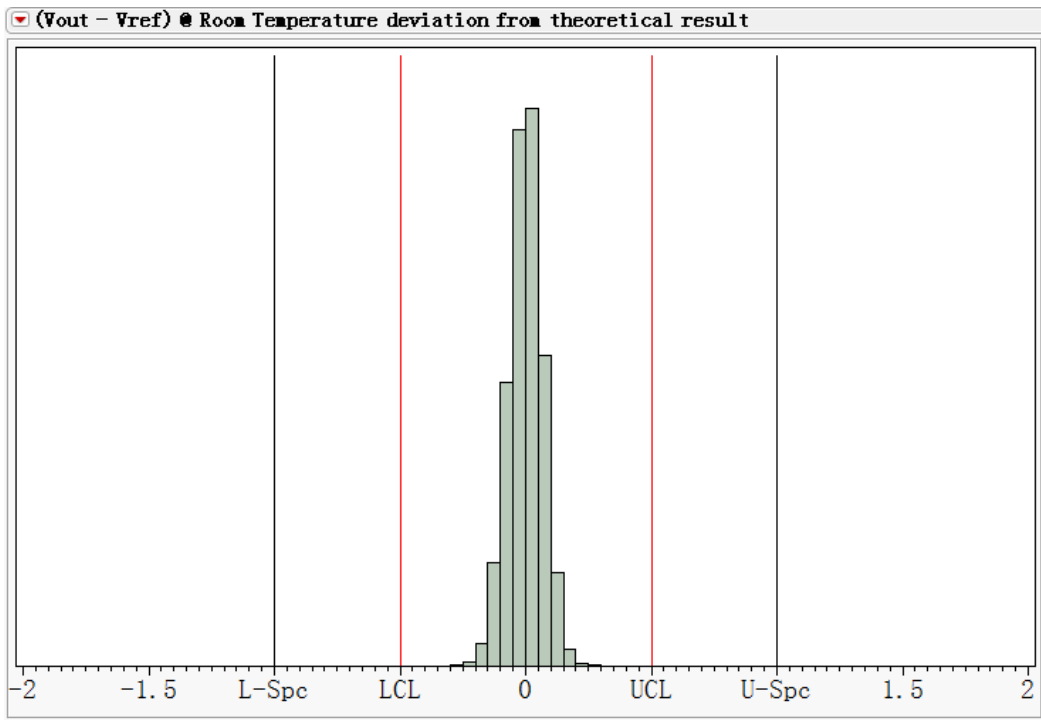

The error of STK-PL/Z3 current sensor at 25 °C compared with the standard output, $((V_{out} - V_{ref})_{measure} @ I_n @ 25^{\circ}C - V_{oe}@25^{\circ}C - G_{th} * I_n) / V_{FS}$. V_{out} represents voltage of V_{out} , V_{ref} the voltage of V_{ref} , I_n the primary current, V_{oe} the $(V_{out} - V_{ref})@0A$, G_{th} the theoretical gain, V_{FS} the rated output voltage.

6. Accuracy cross temperature

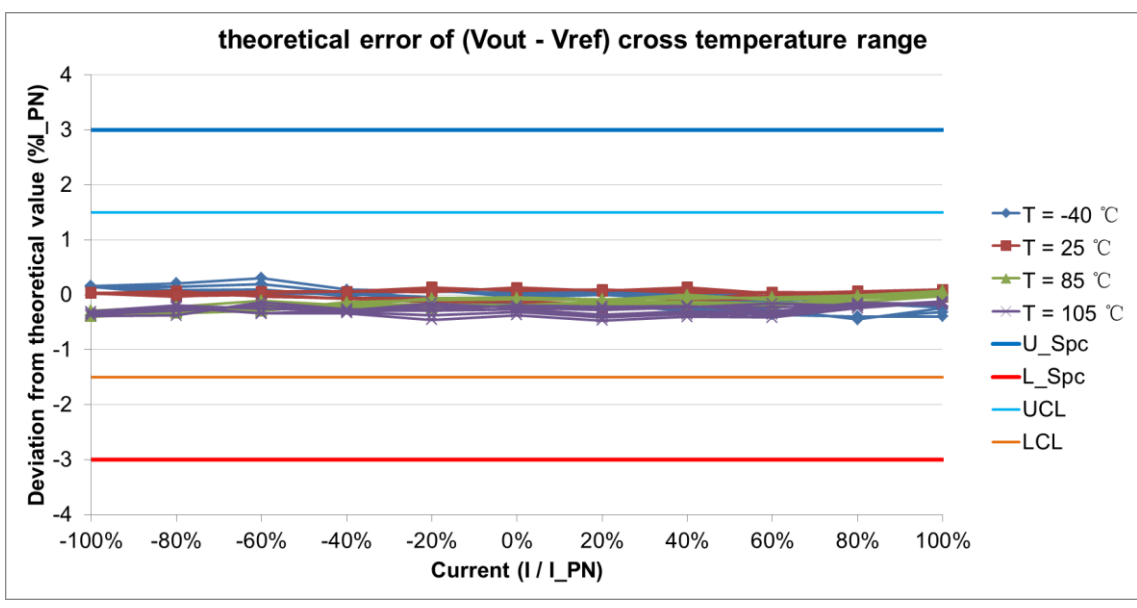

The error of STK-PL/Z3 current sensor at -40 °C ~105 °C compared with the standard output at room temperature, $((V_{out} - V_{ref})_{measure} @ I_n @ T_x - V_{oe}@ T_x - G_{th} * I_n) / V_{FS}$. Where, V_{out} represents voltage of V_{out} , V_{ref} the voltage of V_{ref} , I_n the primary current, T_x the present temperature, V_{oe} the $(V_{out} - V_{ref})@0A$, G_{th} the theoretical gain, V_{FS} the rated output voltage.

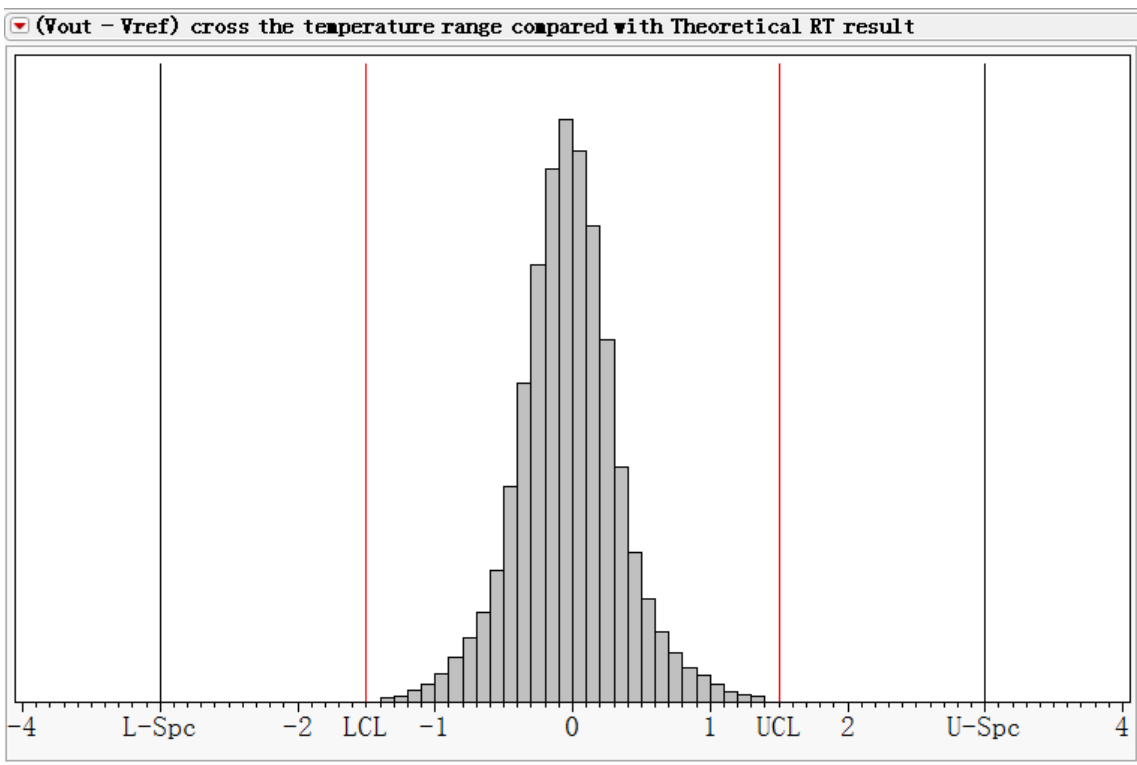

The error of STK-PL/Z3 output ($V_{out} - V_{ref}$) current sensor at $-40^{\circ}\text{C} \sim 105^{\circ}\text{C}$ compared with the standard output ($V = G_{th} * I_n$), $((V_{out} - V_{ref}) @ I_n @ T_x - G_{th} * I_n) / V_{FS}$, Where, I_n represents present primary current, T_x the present temperature, G_{th} the theoretical gain, V_{FS} the rated output voltage.

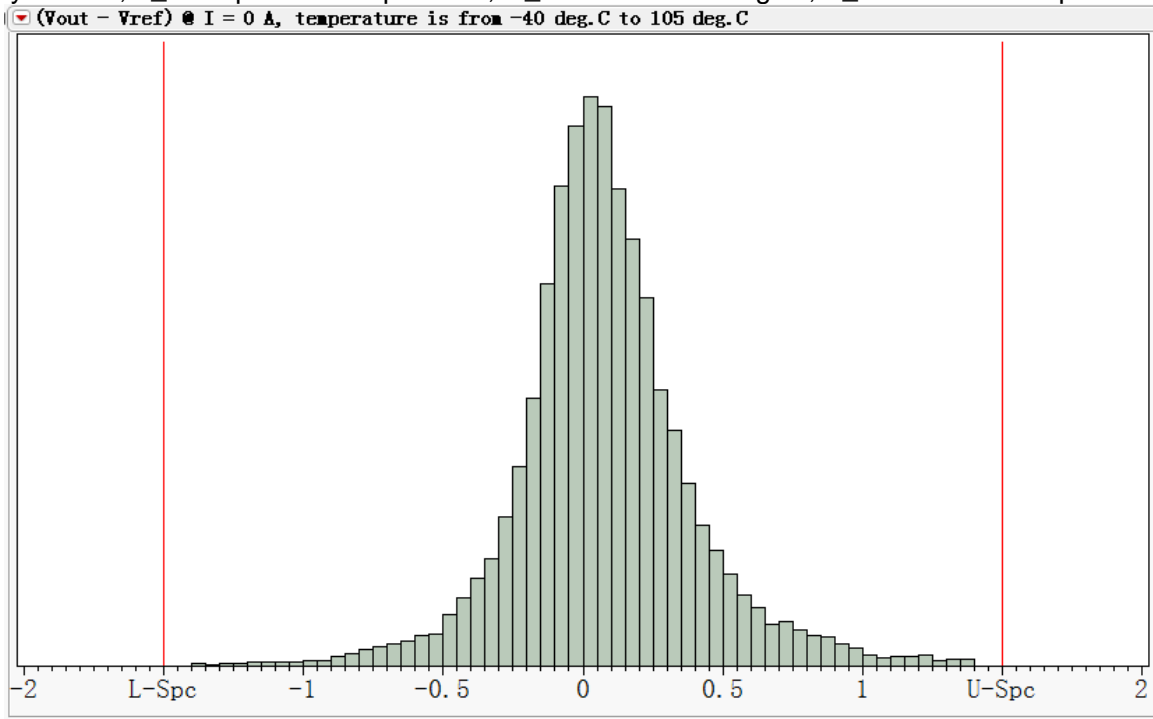

Temperature drift of V_{oe} , $V_{oe_TRange} = (V_{oe} @ T_x - V_{oe} @ 25^{\circ}\text{C}) / V_{FS}$. T_x represents present temperature, V_{FS} the rated output voltage.

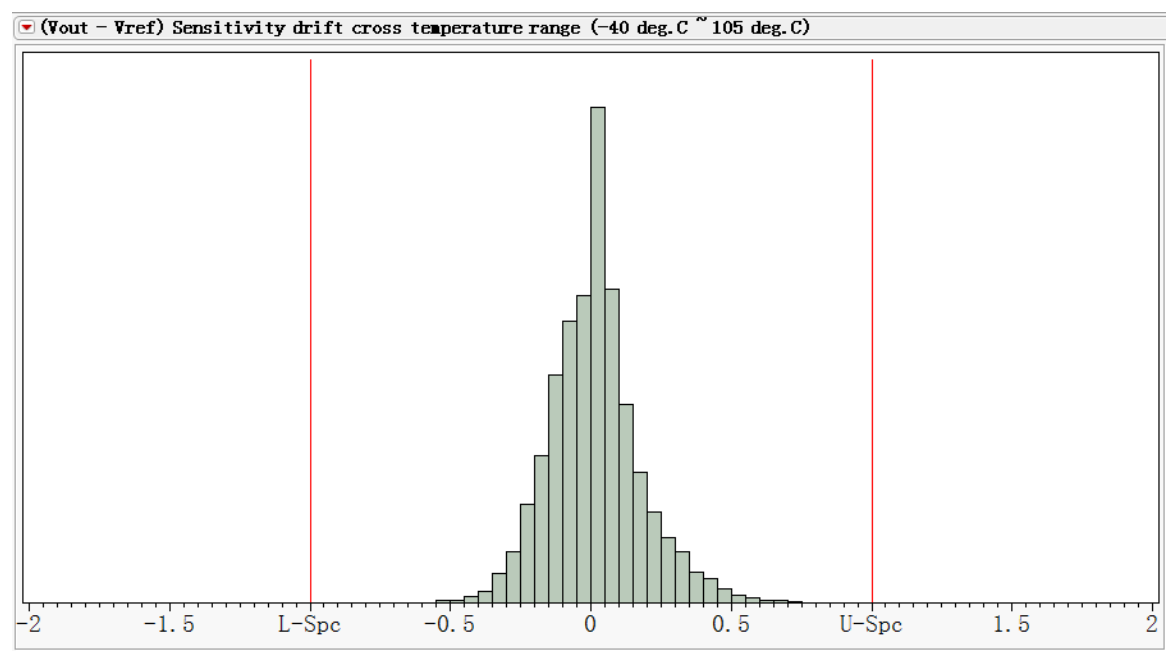

Error of gain, $Err_G = \frac{((V_{out} - V_{ref}) @ I_{pn} - (V_{out} - V_{ref}) @ (-I_{pn})) / 2 - V_{FS}}{V_{FS}}$. Where I_{pn} represents the rated current, $-I_{pn}$ the reversed rated current.

7. Frequency response and bandwidth

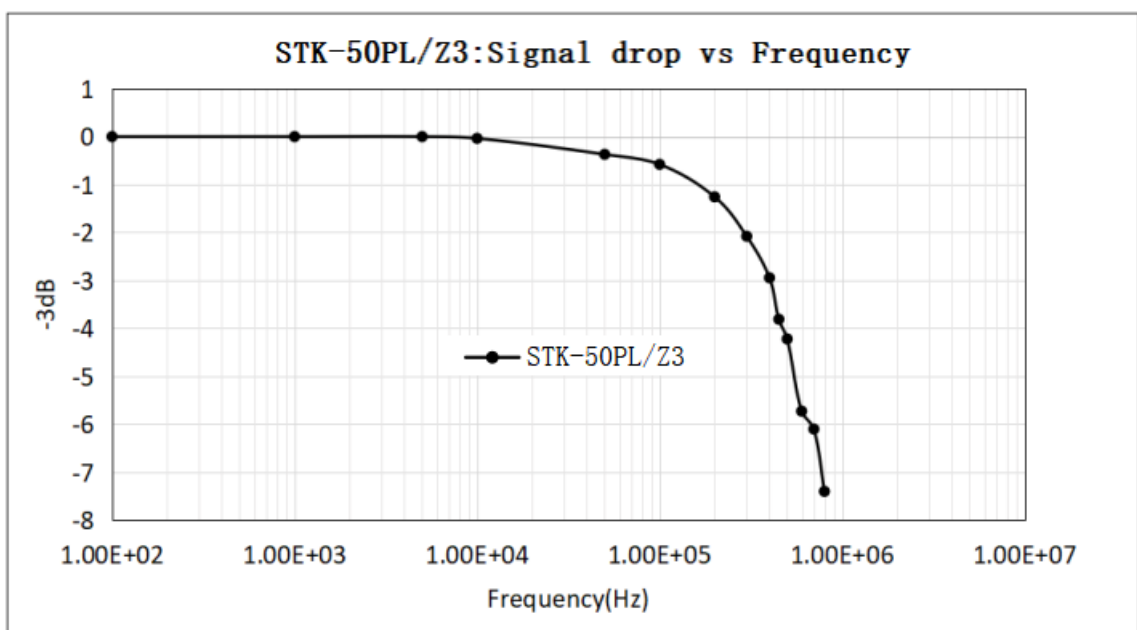

The frequency bandwidth of STK-xxPL/Z3 series current sensor. The bandwidth of current sensor is DC ~ 400 kHz (-3dB).

8. Step response time

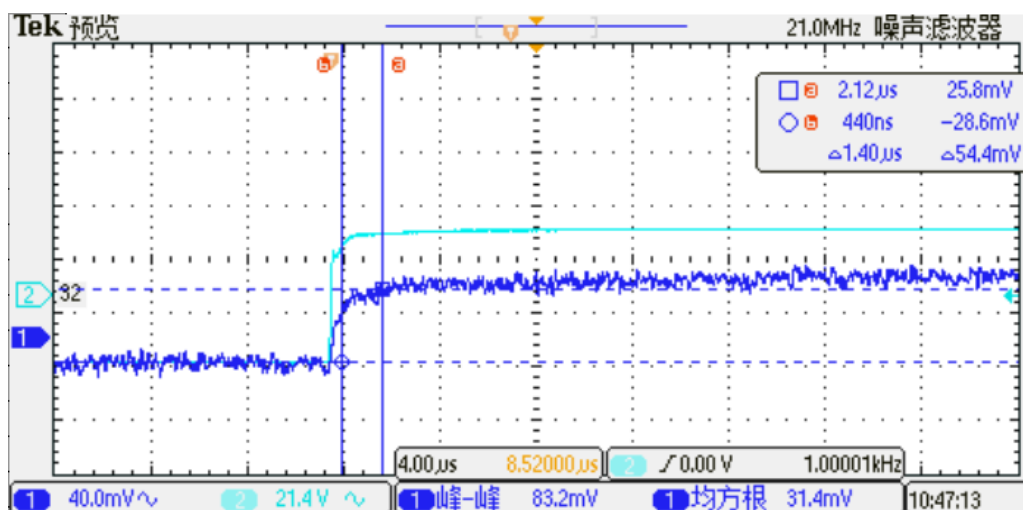

The typical frequency response of STK-xxPL/Z3 current sensor. The response time from 90% of the primary current (light blue) to 90% of the secondary output (dark blue) is less than 1.5 µs

9. Frequency delay performance

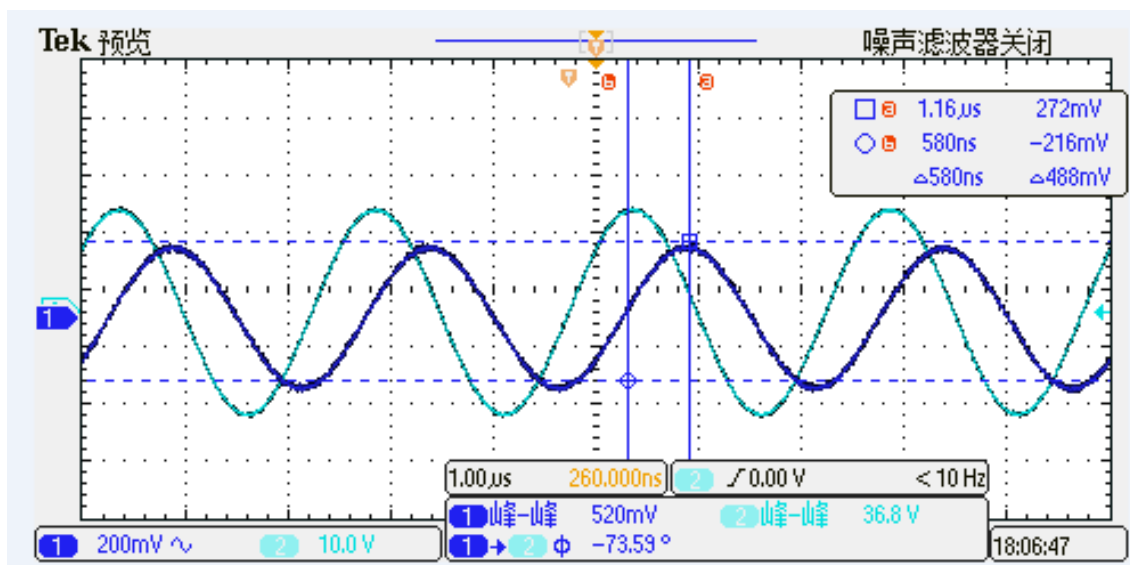

When testing 400 kHz sine wave, the typical result of STK-xxPL/Z3 current sensor's output. The response time from the primary current (light blue) to the secondary output (dark blue) is less than 0.8µs.

10. Recommended PCB layout

Installation of view: overlooking (unit: mm)

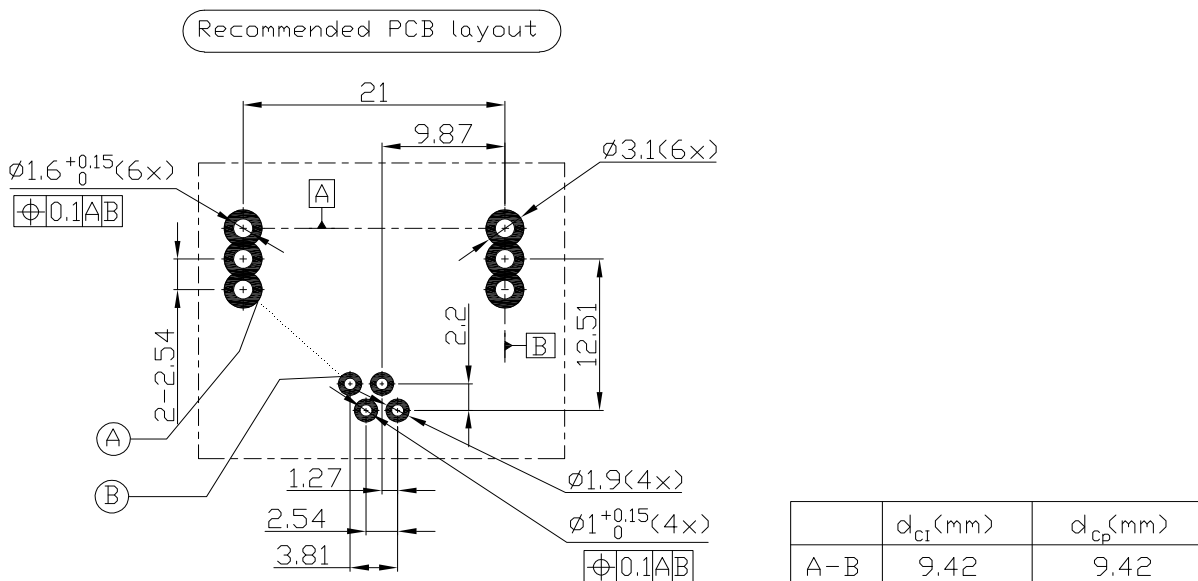

1. Installing angle: Overlook (observe from the side of installing transducer)
2. Recommended bore diameter of primary current line, (diameter of primary current $\times 1.2$) mm
3. Recommended bore diameter of secondary current line, (diameter of secondary current $\times 1.2$) mm
4. The maximum thickness of PCB is 2.5 mm
5. The curve of wave soldering: $260^{\circ}\text{C} \times 10 \text{ s}$



Security:

This current sensor must be used in limited-energy secondary circuit according to IEC 61010-1.

- This current sensor must be used in electric/electronic equipment with respect to appliance standards and safety requirement in accordance with the manufacture's operating instructions;
- When operating the current sensor, certain parts of the module can carry hazardous voltage;
- Failure to wiring as shown in the diagram will damage the current sensor;
- Ignoring this warning can lead to serious consequences.
- A protective housing or a additional shield could be used.
- Main supply must be able to disconnected.

11. Dimension & Pin definitions

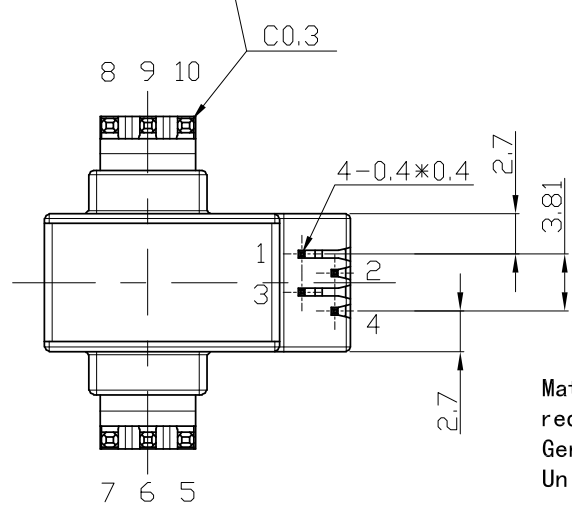
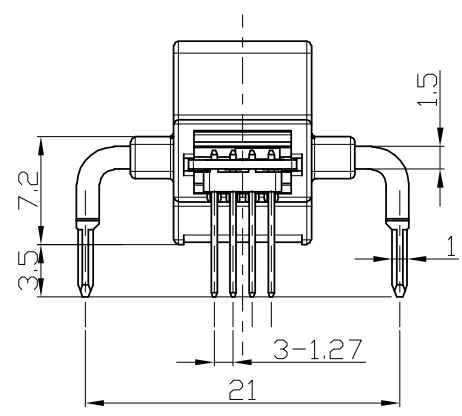
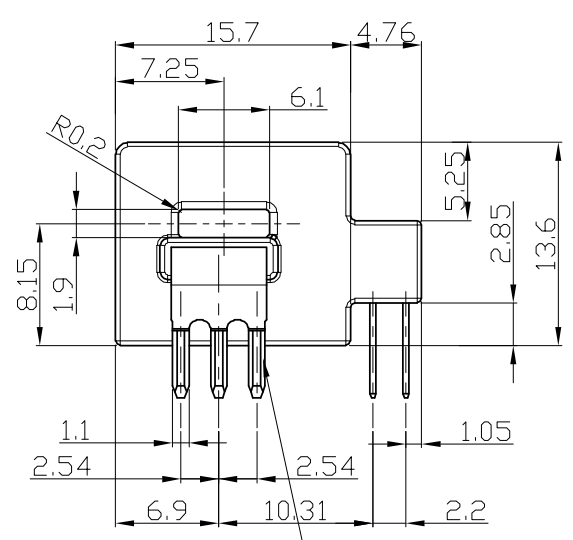
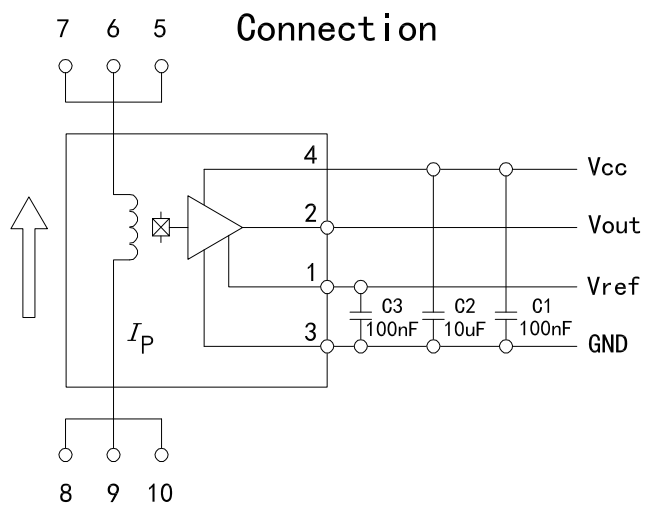
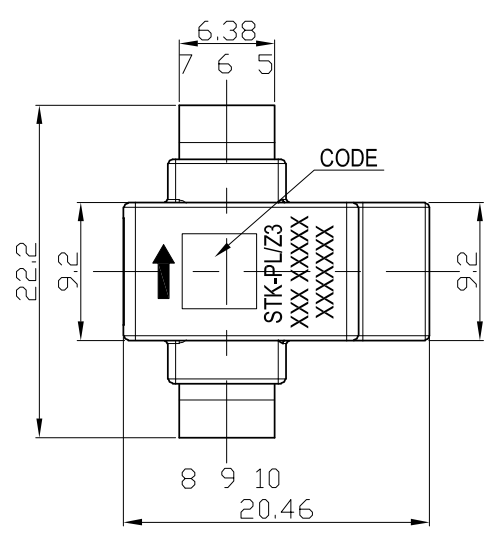

Terminal Pin Identification

- 1 : V_{ref}
- 2 : V_{out}
- 3 : GND
- 4 : V_{cc}
- 5, 6, 7 : Primary input Current (-)
- 8, 9, 10 : Primary input Current (+)

Material : Fit UL94V-0 & RoHS requirements ;
 General tolerance : ± 0.5
 Unit : mm

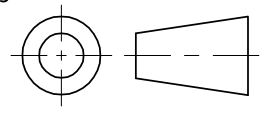

12. Appendix: typical application circuit

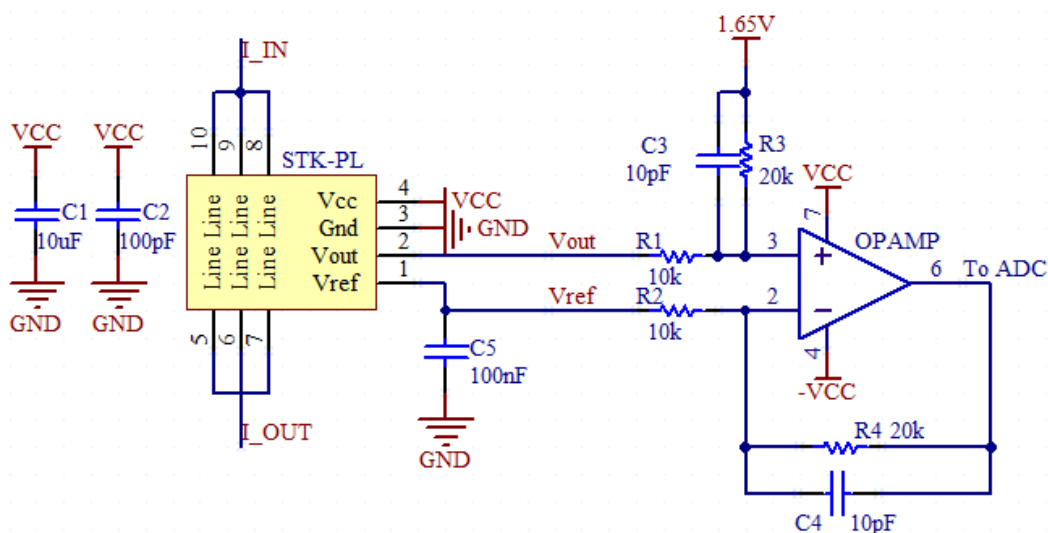
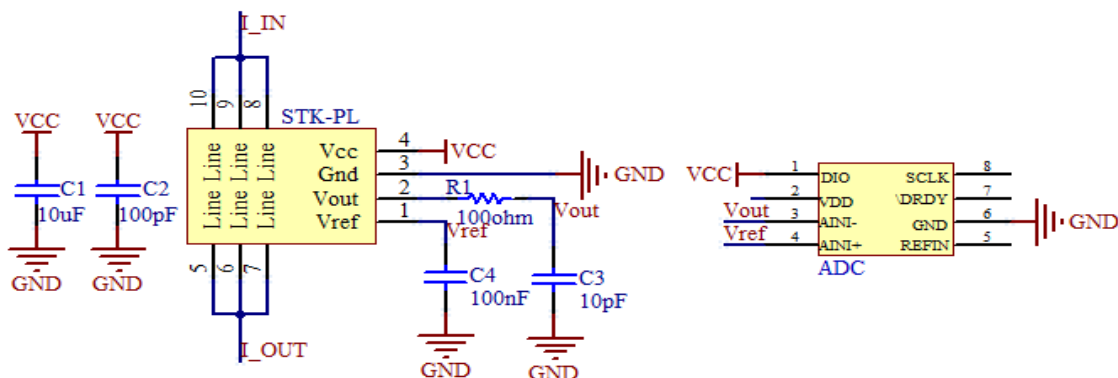

R3 (kohm)	C3 (pF)	Theoretical -3dB $f = 1/(2\pi RC)$ (kHz)	Measured -3dB (kHz)
20	20	398	~400
20	81	98	~ 100
20	810	10	~ 10

The frequency characteristics of STK-xxPL/Z3 series current sensor are not affected by the R-C setting (according to recommended R-C setting), therefore the active filter circuit or R-C circuit can be applied to modulate the sensor's frequency characteristics.

The signal input to ADC is $1.65 + R4/R2 * (Vout - Vref)$ with the conditions: $R1 = R2, R3 = R4, C3 = C4$.