



CURRENT SENSOR

PRODUCT SERIES: SFG-x.xP/SN

PRODUCT PART NUMBER: SFG-0.3P/SN;SFG-1.0P/SN;

REVISION: Ver 1.1



Sinomags Technology Co., Ltd.

Website: www.sinomags.com

CONTENT

1. Description.....	2
2. Absolute parameter.....	3
3. SFG-0.3P/SN Electrical data.....	4
4. SFG-1.0P/SN Electrical data.....	5
5. Application information.....	6
6. Dimensions (in mm).....	7
7. Assembly on PCB.....	8

1. Description

Features

- Open loop current transducer
- Voltage output
- Insulation voltage for 5kV/AC
- Single supply voltage
- PCB mounting
- Cobalt base magnetic ring.

Applications

- Residual current measurement
- Leakage current measurement in transformerless PV inverters
- First human contact protection of PV arrays
- Failure detection in power sources
- Leakage current detection in stacked DC sources
- Communication power

Advantages

- High accuracy
- High overload capability
- High insulation capability
- High separation ability
- Low temperature drift
- Degauss and test functions.

Standards

- IEC 61326-1: 2012
- N 50178

Application Domain

- Industry.

2. Absolute parameter

Absolute maximum ratings

Parameter	Symbol	Unit	Value
Supply voltage	V_c	V	5.5
Primary conductor temperature	$T_{B \max}$	°C	110
Overload capability (100 μ s, 500 A/ μ s)	$\hat{I}_{P \max}$	A	3300

Stresses above these ratings may cause permanent damage. Exposure to absolute maximum ratings for extended periods may degrade reliability.

Isolation parameters

Parameter	Symbol	Unit	Value
RMS voltage for AC test 50Hz/1min	V_d	kV	5
Impulse withstand voltage 1.2/50 μ s	V_w	kV	10.1
Comparative tracking index	CTI	V	600
Case material			V0 according to UL 94

Environmental and mechanical characteristics

Parameter	Symbol	Unit	Min	Typ	Max
Ambient operating temperature	T_A	°C	-40		105
Ambient storage temperature	T_S	°C	-45		125
Mass	m	g		30	
standard	EN 50178, IEC 61010-1, UL 508				

3. SFG-0.3P/SN Electrical data

At $T_A = 25^\circ\text{C}$, $V_C = 5\text{ V}$.

Parameters	Symbol	Unit	Min	Typ	Max	Remark
Primary nominal residual rms current	I_{pn}	A		0.3		
Primary residual current, measuring range	I_{pm}	A	-0.5		0.5	
Supply voltage	V_C	V	4.9	5	5.1	
Current consumption	I_C	mA		18		$I_P(\text{mA}) / N_a$ $N_a = 40$ turns -40°C ... 105°C
Reference voltage @ $I_P = 0$	V_{ref}	V	2.475	2.5	2.525	Internal reference
Temperature coefficient of V_{ref} @ $I_P = 0$	TCV_{ref}	ppm/K		± 100	± 250	ppm/K of 2.5 V -40 ... 105 °C
Electrical offset voltage	V_{oe}	mV	-25		25	$(V_{out} - V_{ref})$ @ 0 A
Quiescent voltage	V_{off}	V	2.45	2.5	2.55	$V_{out}@0A$
Temperature coefficient of V_{OE} @ $I_P = 0$	TCV_{oe}	ppm/K		± 100	± 300	ppm/K of 2.5 V -40 ... 105 °C
Theoretical sensitivity	G_{th}	V/A		4		
Temperature coefficient of G_{th}	TCG	ppm/K		± 300	± 400	-40°C ... 105°C
Sensitivity error	ϵ_G	%	-2	1	2	
Linearity error	ϵ_L	%		0.5	1	
Check current	I_{CK}	mA		50		Sum of 20turns
Output voltage(Checkfunction)	V_{CK}	V	$V_{oe}+$ 0.19	$V_{oe}+0.2$	$V_{oe}+$ 0.21	
Check enable voltage	V_{CE}	V	3.3		V_C	
Check disabled voltage	V_{CD}	V		< 0.2		
Frequency bandwidth (-3dB)	BW	Hz		700		
Noise(1 Hz ~ 10 kHz)	V_{no}	mV rms		10		
Reaction time @ 10 % of I_{PN}	t_{ra}	μs		100		$R_L > 500\text{ k}\Omega$, $di/dt > 5\text{ A}/\mu\text{s}$
Step response time to 90 % of I_{PN}	t_r	μs		700		$R_L > 500\text{ k}\Omega$, $di/dt > 5\text{ A}/\mu\text{s}$
Accuracy @ $I_{PN}@T_A = 25^\circ\text{C}$	$X_{25^\circ\text{C}}$	% of I_{PN}		± 2		
Accuracy @ I_{PN} @ $T_A = 105^\circ\text{C}$	$X_{105^\circ\text{C}}$	% of I_{PN}		± 4		
Output internal resistance	R_{out}	Ω		49.9		
V_{ref} internal resistance	R_{ref}	Ω		49.9		

4. SFG-1.0P/SN Electrical data

At $T_A=25^{\circ}\text{C}$, $V_C=5\text{ V}$.

Parameters	Symbol	Unit	Min	Typ	Max	Remark
Primary nominal residual rms current	I_{pn}	A		1		
Primary residual current, measuring range	I_{pm}	A	-1.7		1.7	
Supply voltage	V_C	V	4.9	5	5.1	
Current consumption	I_C	mA		18		$I_P(\text{mA}) / N_a$ $N_a = 40$ turns - $40^{\circ}\text{C} \dots 105^{\circ}\text{C}$
Reference voltage @ $I_P = 0$	V_{ref}	V	2.475	2.5	2.525	Internal reference
Temperature coefficient of V_{ref} @ $I_P = 0$	TCV_{ref}	ppm/K		± 100	± 250	ppm/K of 2.5 V - $40 \dots 105^{\circ}\text{C}$
Electrical offset voltage	V_{oe}	mV	-25		25	$(V_{out} - V_{ref})$ @ 0 A
Quiescent voltage	V_{off}	V	2.45	2.5	2.55	$V_{out}@0A$
Temperature coefficient of V_{OE} @ $I_P = 0$	TCV_{oe}	ppm/K		± 100	± 300	ppm/K of 2.5 V - $40 \dots 105^{\circ}\text{C}$
Theoretical sensitivity	G_{th}	V/A		1.2		
Temperature coefficient of G_{th}	TCG	ppm/K		± 300	± 400	- $40^{\circ}\text{C} \dots 105^{\circ}\text{C}$
Sensitivity error	ϵ_G	%	-2	1	2	
Linearity error	ϵ_L	%		0.5	1	
Check current	I_{CK}	mA		166		Sum of 20turns
Output voltage(Checkfunction)	V_{CK}	V	V_{oe+} 0.19	$V_{oe+0.2}$	V_{oe+} 0.21	
Check enable voltage	V_{CE}	V	3.3		V_C	
Check disabled voltage	V_{CD}	V		< 0.2		
Frequency bandwidth (-3dB)	BW	Hz		700		
Noise(1 Hz ~ 10 kHz)	V_{no}	mV rms		10		
Reaction time @ 10 % of I_{PN}	tra	μs		100		$RL > 500\text{ k}\Omega$, $di/dt > 5\text{ A}/\mu\text{s}$
Step response time to 90 % of I_{PN}	tr	μs		700		$RL > 500\text{ k}\Omega$, $di/dt > 5\text{ A}/\mu\text{s}$
Accuracy @ $I_{PN}@T_A=25^{\circ}\text{C}$	$X_{25^{\circ}\text{C}}$	% of I_{PN}		± 2		
Accuracy @ I_{PN} @ $T_A=105^{\circ}\text{C}$	$X_{105^{\circ}\text{C}}$	% of I_{PN}		± 4		
Output internal resistance	R_{out}	Ω		49.9		
V_{ref} internal resistance	R_{ref}	Ω		49.9		

5. Application information

Application circuit

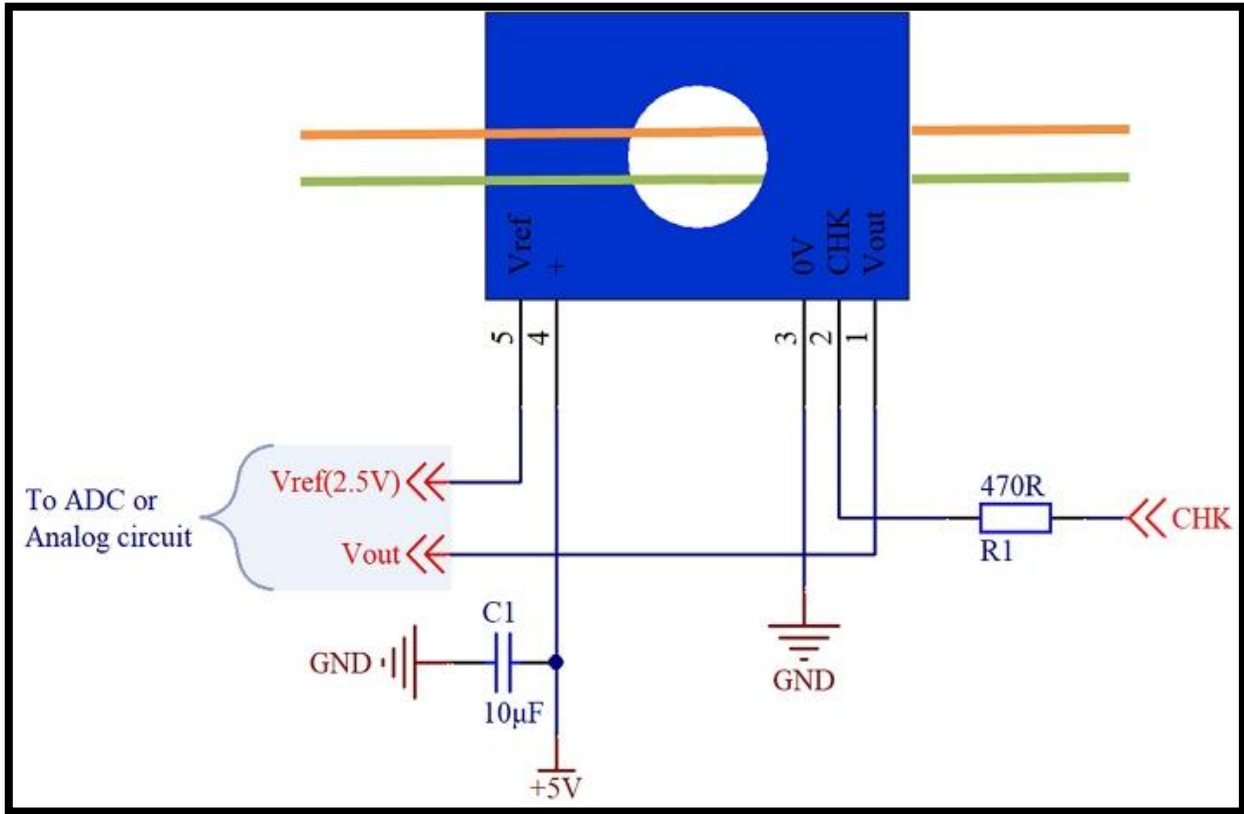

Self-check Function

Set the CHK pin to high status. SFG-x.xP/Sx will run in self-test mode, check the out pin, equivalent to the status I_p is I_{ck} , at this time the output has equivalent voltage, the detector is OK. Then sets CHK to low voltage $V_{CD} < 0.2V$, the sensor starts to run in the residual current.

6. Dimensions (in mm)

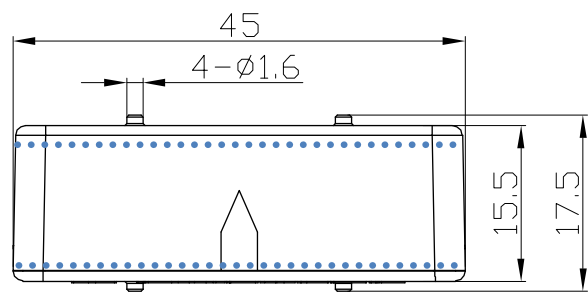

..... : Internal magnetic shielding

Terminals:

1	Vout
2	CHK
3	GND
4	Vcc
5	Vref

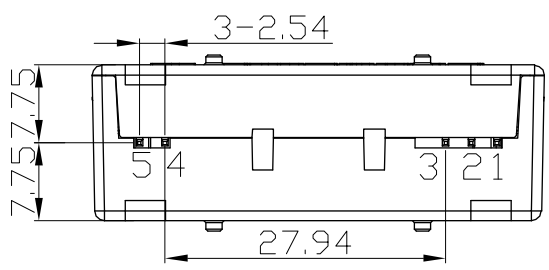
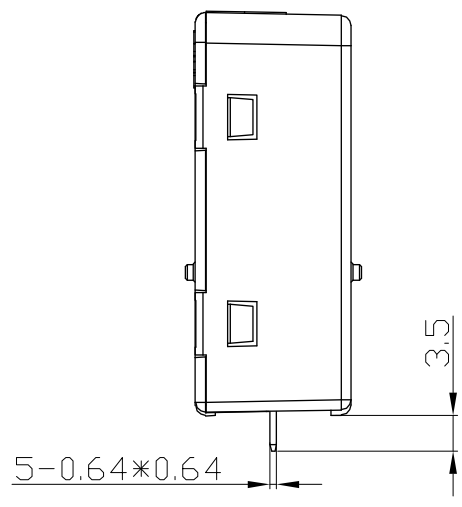
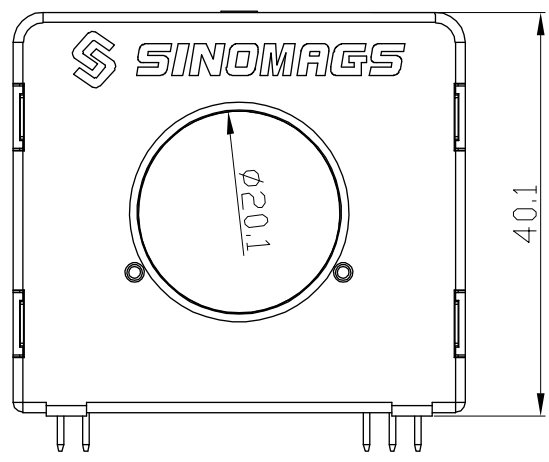

Material : Fit UL94V-0 & RoHS requirements ;
General tolerance : ± 0.5
Unit :mm

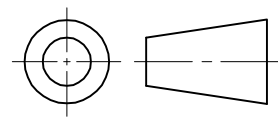

7. Assembly on PCB

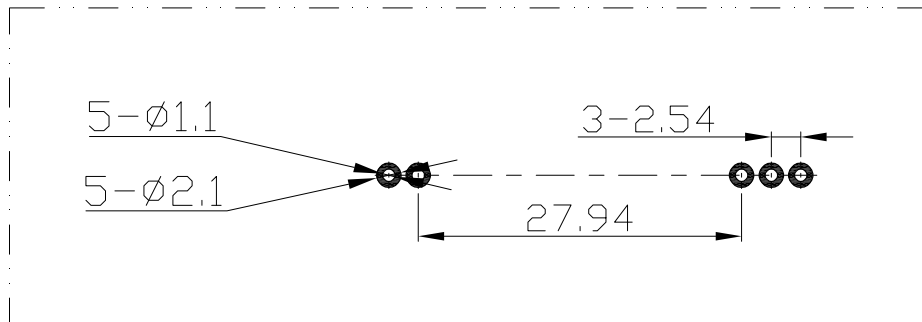

- Maximum PCB thickness 2.4 mm
- Wave-soldering: 260°C @ 10 s
- Recommended PCB hole diameter 1.2 mm for secondary pin.