



Current Sensor

Product Series: SHK-VBS3-SA/SHK-VBS3-SC

SHK-VBS3-1000-SA/SHK-VBS3-1000-SC

SHK-VBS3-1100-SA/SHK-VBS3-1100-SC

SHK-VBS3-1200-SA/SHK-VBS3-1200-SC

Part number: SHK-VBS3-1300-SA/SHK-VBS3-1300-SC

SHK-VBS3-1400-SA/SHK-VBS3-1400-SC

SHK-VBS3-1500-SA/SHK-VBS3-1500-SC

SHK-VBS3-1600-SA/SHK-VBS3-1600-SC

VERSION: Ver 1.1

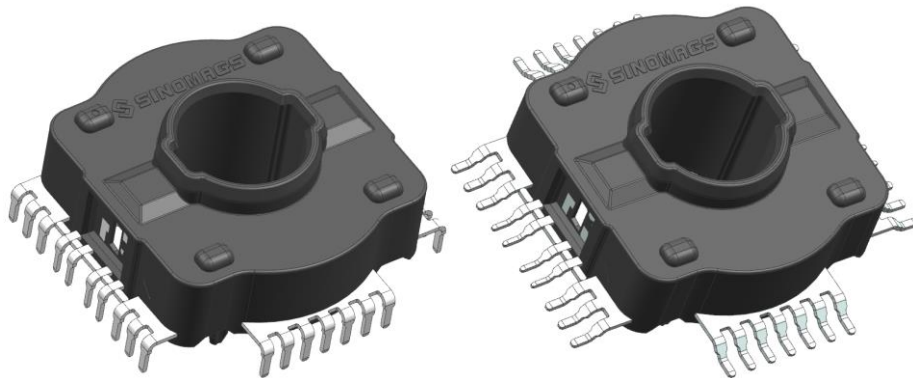

Sinomags Technology Co., Ltd

Web site: www.sinomags.com

CONTENT

1.	Description	2
2.	Electrical data	3
3.	Dimension & Pin definitions	6
4.	Applications	8

1. Description

The SHK-VBS3-SA/SHK-VBS3-SC current sensor is based on Hall and open-loop design. It is suitable for DC, AC pulsed and any kind of irregular current measurement under the isolated conditions.

Typical applications

- AC Variable speed drives
- Electric welder power supply
- Inverter
- Switched model power supplies (SMPS)

General parameter

Parameter	Symbol	Unit	Value
Working temperature	T_a	°C	-40 ~ 125
Storage temperature	T_{stg}	°C	-40 ~ 125
Mass	m	g	30

Absolute maximum rating

Parameter	Symbol	Unit	Value
Supply voltage	Vcc	V	6.5
Electrostatic discharge voltage	$U_{ESD\ HBM}$	kV	2

Remark: the unrecoverable damage may occur when the product works on the conditions over the absolute maximum ratings. Long-time working on the absolute maximum ratings may cause the degradation on performance and reliability.

Isolation parameter

Parameter	Symbol	Unit	Value	Comment
Insulation voltage	U_d	kV	3.6	RMS voltage for AC test 50Hz-1 min, OV III altitude 400 m
Clearance distance (pri. -sec)	d_{Cl}	mm	5	Shortest distance through air
Creepage distance (pri. -sec)	d_{Cp}	mm	11	Shortest path along device body
Comparative tracking index	CTI		PLC 3	
Case material			V0 according to UL 94	

2. Electrical data

 Condition: $T_a = 25^\circ\text{C}$, $V_{CC} = 5.0\text{ V}$

Parameter	Symbol	Unit	Min	Typ	Max	Comment
Primary current measuring range	I_{PM}	A	-1000		1000	SHK-VBS3-1000-SA
			-1100		1100	SHK-VBS3-1100-SA
			-1200		1200	SHK-VBS3-1200-SA
			-1300		1300	SHK-VBS3-1300-SA
			-1400		1400	SHK-VBS3-1400-SA
			-1500		1500	SHK-VBS3-1500-SA
			-1600		1600	SHK-VBS3-1600-SA
Primary current measuring range	I_{PM}	A	-1000		1000	SHK-VBS3-1000-SC
			-1100		1100	SHK-VBS3-1100-SC
			-1200		1200	SHK-VBS3-1200-SC
			-1300		1300	SHK-VBS3-1300-SC
			-1400		1400	SHK-VBS3-1400-SC
			-1500		1500	SHK-VBS3-1500-SC
			-1600		1600	SHK-VBS3-1600-SC
Supply voltage	V_{CC}	V	4.85	5	5.15	All
Current consumption	I_{CC}	mA		28	35	@ $V_{CC} = 5.0\text{ V}$
Quiescent voltage	V_{off}	V	$V_{CC}/2 \pm 0.025$			@ $T_a = 25^\circ\text{C}$, $V_{CC} = 5.0\text{ V}$
Sensitivity	G	mv/A		2		SHK-VBS3-1000-SA
				1.82		SHK-VBS3-1100-SA
				1.67		SHK-VBS3-1200-SA
				1.54		SHK-VBS3-1300-SA
				1.43		SHK-VBS3-1400-SA
				1.33		SHK-VBS3-1500-SA
				1.25		SHK-VBS3-1600-SA
Sensitivity	G	mv/A		2		SHK-VBS3-1000-SC
				1.82		SHK-VBS3-1100-SC
				1.67		SHK-VBS3-1200-SC
				1.54		SHK-VBS3-1300-SC
				1.43		SHK-VBS3-1400-SC
				1.33		SHK-VBS3-1500-SC
				1.25		SHK-VBS3-1600-SC

Load resistance	R_L	k Ω			10	
Ratiometricity error	ϵ_r	%		± 0.5		@ $4.75V \leq V_{CC} \leq 5.25V$
Sensitivity error	ϵ_G	%		± 1		@ $T_a = 25^\circ C$
Electrical offset voltage error	V_{OE}	mV		± 4		@ $T_a = 25^\circ C$, $V_{CC} = 5.0 V$
Magnetic offset voltage error	V_{OM}	mV		± 5		@ $T_a = 25^\circ C$, $V_{CC} = 5.0 V$
Ave. Temp. coefficient of V_{OE}	TCV_{OEAV}	mV/ $^\circ C$		± 0.1		@ $-40^\circ C < T_a < 125^\circ C$
Ave. Temp. coefficient of S	TCS_{AV}	%/ $^\circ C$		± 0.03		@ $-40^\circ C < T_a < 125^\circ C$
Linearity error	ϵ_L	% I_P		± 1		
Response time	T_r	μs		2	4	@ 90% of I_{PM}
Frequency bandwidth (-3 dB)	BW	kHz		40		No RC circuit
Output voltage noise	V_{no}	mVpp			15	@ DC ~ 10 kHz

SHK-VBS3-SA/SHK-VBS3-SC: Overall accuracy X
@ Vcc 5V (-40°C ≤ Ta ≤ 125°C)
absolute error



Overall accuracy X specification(mV)		
I _{PM} (A)	@Ta = 25°C, VCC = 5.0V	@-40°C ≤ Ta ≤ 125°C, VCC = 5.0V
-1600	35	60
-1500	33.4	57.5
-1400	32	54.8
-1300	30.6	52.2
-1200	29.2	49.5
-1100	27.8	46.9
-1000	26.4	44.2
0	12	18
1000	26.4	44.2
1100	27.8	46.9
1200	29.2	49.5
1300	30.6	52.2
1400	32	54.8
1500	33.4	57.5
1600	35	60

3. Dimension & Pin definitions

3.1 SHK-VBS3-SA

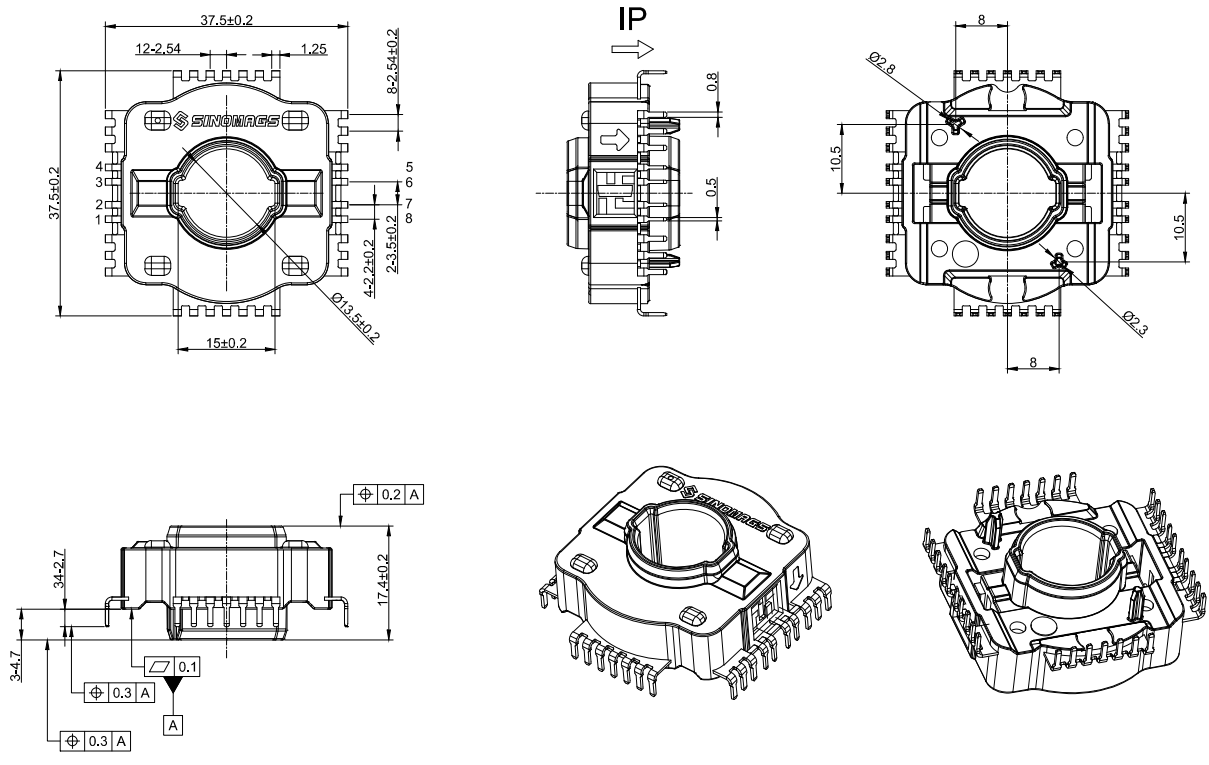

Material : Fit UL94V-0 & RoHS requirements ;
 General tolerance : ±0.5
 Unit :mm

Terminals:

Pin1	Vout1
Pin2	Vcc1
Pin3	GND
Pin4	NC
Pin5	Vout2
Pin6	Vcc2
Pin7	GND2
Pin8	NC

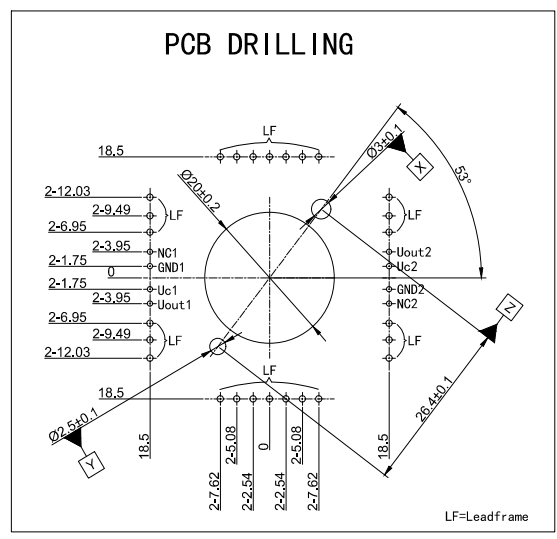
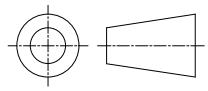

3.2 SHK-VBS3-SC

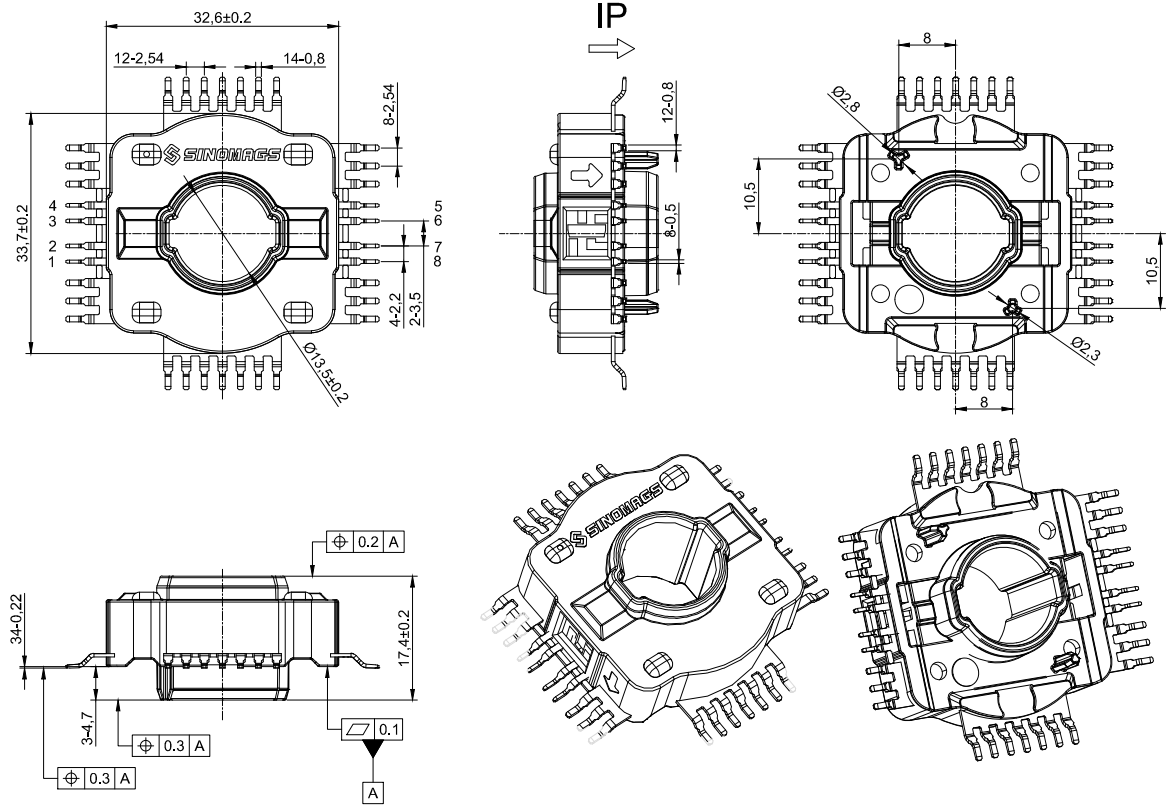

Material : Fit UL94V-0 & RoHS requirements ;
 General tolerance : ± 0.5
 Unit :mm

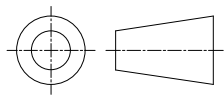

Terminals:

Pin1	Vout1
Pin2	Vcc1
Pin3	GND
Pin4	NC
Pin5	Vout2
Pin6	Vcc2
Pin7	GND2
Pin8	NC

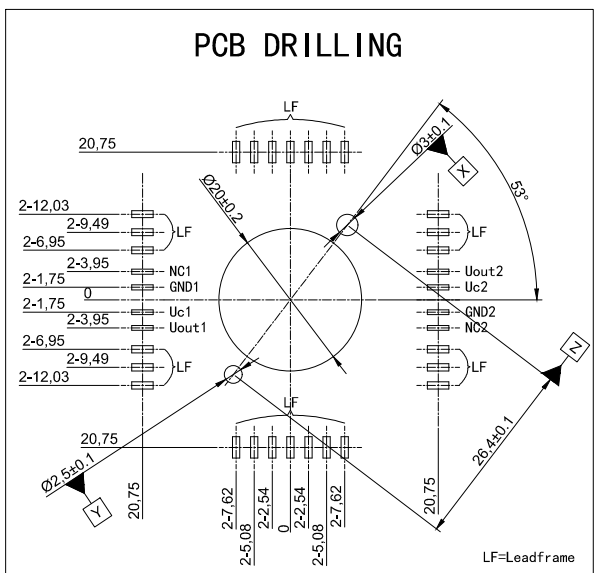

4. Applications

Customers have to compute the Average value of Uout 1 and Uout 2, This can be achieved through the circuit shown in schematic 1 or any other method defined by the customer (as shown in schematic 2).

Schematic 1:

Example of transducer output averaging with passive components.

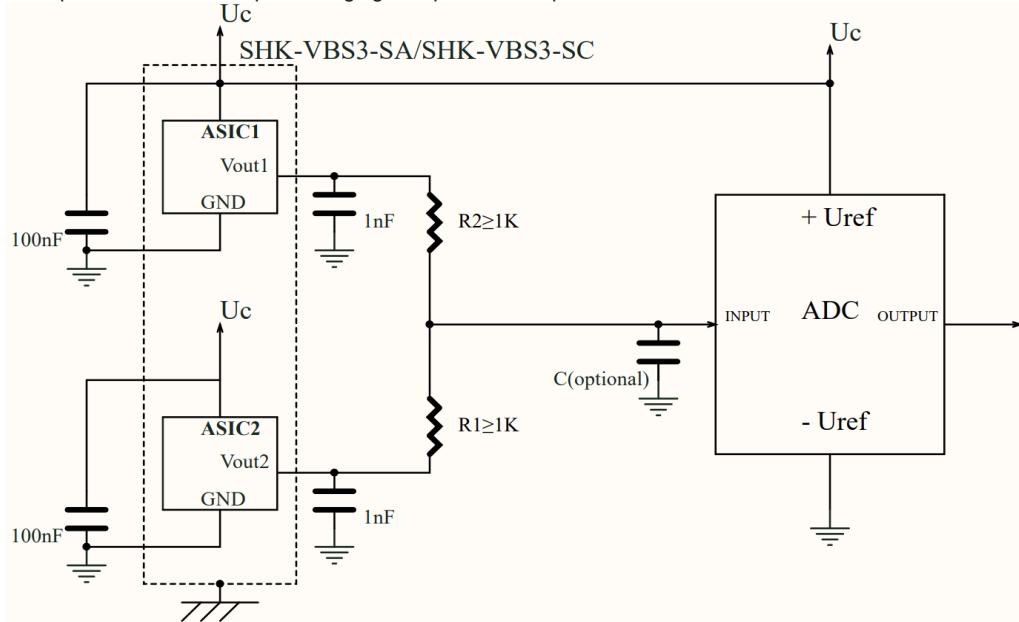

Resistance: $R \geq 1\text{ K}$, 1%, 100 ppm/°C, 100 mW, 75 V, -40 ... 155 °C, 0603 (or better)

Schematic 2:

Example of transducer averaging with a micro-controller.

SHK-VBS3-SA/SHK-VBS3-SC

